

GUIDANCE FOR THE STORAGE, HANDLING AND  
TRANSPORTATION OF SOLID MINERAL FERTILIZERS

APRIL 2007

*efma* european fertilizer manufacturers association



The following table can be used to facilitate a search of the main topics

<b>Aspect or topic</b>	<b>Chapter Number</b>
Product range and materials	5
Properties	5
Hazards	6, 17
Storage recommendations	9, 10, 11
Classification and legislation	7, 8
Maintenance	13
Off-spec and reject materials	12
Transport	7, 14
Safety and security	15, 16
Emergency plans	18
Environment	17

**Copyright 2007-EFMA**

EUROPEAN FERTILIZER MANUFACTURERS' ASSOCIATION  
AVE. E. VAN NIEUWENHUYSE 4  
B-1160 BRUSSELS  
BELGIUM

## CONTENTS

1.	Introduction, Scope and Objectives	2
2.	Product Stewardship	4
3.	General Information	5
4.	Historical Perspective	11
5.	General Properties	13
6.	Hazardous Properties	24
7.	Classification	30
8.	Legislation	33
9.	Methods of Handling and Storage	35
10.	Recommendations and Requirements for the Storage of All Fertilizers	39
11.	Additional Recommendations and Requirements for the Storage of Classified Fertilizers (UN 2067 and 2071)	48
12.	Management of Non-conforming and Ancillary Materials	52
13.	Maintenance of Equipment and Vehicles	54
14.	Transport	56
15.	Safety Facilities and Training	61
16.	Security	63
17.	Consequence Analysis and Environmental Considerations	64
18.	Emergency Procedures	67
19.	References	70
20.	Abbreviations	73
	<b>APPENDICES</b>	<b>76</b>
	1 Classification of Fertilizers Under the UN Scheme	
	2 Provisions of Seveso II Directive	
	3 Victor Lances	

Prepared by EFMA – April 2007

*DISCLAIMER:*

*The information and guidance provided in this document is given in good faith. EFMA, its members, consultants and staff accept no liability for any loss or damage arising from the use of this guidance.*

## 1. INTRODUCTION, SCOPE AND OBJECTIVES

- 1.1 This guidance is for use by manufacturers, importers, merchants, hauliers, farmers, and everyone concerned with the storage, handling and transportation of solid fertilizers. Its purpose is to promote safety and preserve the quality of fertilizers in storage, handling and transport, to safeguard the health of personnel and to avoid hazards to the environment.
- 1.2 It sets out requirements and recommendations for the handling and storage of fertilizers focussing on AMMONIUM NITRATE BASED FERTILIZERS OR AN BASED FERTILIZERS. The requirements and recommendations are based on their specific properties. All fertilizers are stable materials which present minimal risk when stored, handled and transported correctly either in bulk or packaged form. This guidance provides advice on conditions in which these activities can be carried out safely.
- 1.3 The legislation relating to the storage of fertilizers varies from country to country for both packages and bulk. This guidance may serve as a reference for the preparation of rules and recommendations on the safe storage, handling and transportation where no national regulations are available. However, it should be noted that national regulations take precedence over this guidance.
- 1.4 This guidance is a revision of the former publication by APEA/IFA in 1992, Handbook for the Safe Storage of Ammonium Nitrate Based Fertilizers (Ref 1). Besides up-dating the information given, EFMA has enlarged the scope of the guidance. It now covers all main solid mineral fertilizers and also security related issues. It considers the environmental aspect in more detail. It suggests ways of good management with a list of basic good practices and also recommends emergency action and first aid procedures. It emphasises the sharing of learning from accidents and recommends the reporting of accidents more widely throughout the industry to facilitate this process.

This guidance does not apply to:

- Liquid (ie fluid) fertilizers
- Forms of ammonium nitrate other than the fertilizer grade (e.g. low density prills)
- Organic and organo-mineral fertilizers.

The management of reject and off-spec fertilizer materials is covered in detail in two separate EFMA guidance documents (Refs 2-3). Hence this subject is only briefly addressed in this guidance in Chapter 12. Readers are strongly advised to consult them as appropriate.

- 1.5 This guidance forms a part of EFMA's product stewardship initiative and as such requires its member companies to comply with its recommendations. Furthermore, all those involved in the distribution and use of fertilizers are strongly advised to follow the recommendations given in this guidance. Strict adherence to the recommendations will minimise the risk of an accident and enable the fertilizers to be stored and handled safely. Continued vigilance is necessary to ensure that the recommendations are followed at all times.

It should be noted that Safety Data Sheets (also called Material Safety Data Sheets in some countries) are provided by manufacturers for their products and they contain much useful information specific to the products.

- 1.6 This guidance is essentially in two parts:
- The first part provides background information, which is covered in Chapters 1 to 9.
  - The second part gives recommendations and requirements, which are described in Chapters 10 to 18.

## 2. PRODUCT STEWARDSHIP

---

Whereas in the past most EFMA members followed various aspects of product stewardship individually, in 2003 EFMA established a formal Product Stewardship (PS) programme for its members.

The EFMA PS Programme is accessible from the EFMA website (Ref 4).

Product Stewardship for the fertilizer industry is ensuring that fertilizers and their raw materials, additives and intermediate products are processed and manufactured, handled, stored, distributed and used in a safe way with regard to health, occupational and public safety, environment, and security.

The PS programme consists of guidance for the implementation of PS in EFMA member companies based on agreed EFMA standards concerning the production, distribution, storage and use of fertilizers. Reference is made to EU legislation, industrial practices and best available techniques. In addition, auditing by an independent third party auditor is required. This guidance is part of EFMA's Product Stewardship programme.

## 3. GENERAL INFORMATION

### 3.1 PLANT NUTRIENTS

Fertilizers are substances which are used to increase crop yields and crop quality by providing one or more of the essential plant nutrients nitrogen (N), phosphorus (P) and potassium (K). These three are primary nutrients and their most common sources are ammonium nitrate, urea, calcium ammonium nitrate and ammonium sulphate (for nitrogen), various phosphates (for phosphorus) and potassium chloride, potassium sulphate or potassium nitrate (for potassium). Fertilizers which contain only one of the nutrients are called straight fertilizers and those which contain more than one, are called compound fertilizers (these can be complex or blend types, see 3.3 next page).

There are also a number of other elements, which plants need; they fall into two categories: secondary nutrients and micronutrients. The secondary nutrients are calcium (Ca), magnesium (Mg), sodium (Na) and sulphur (S). Micronutrients are required in very small amounts (less than 1 kg/ha), but are nonetheless essential. In the EU the following are listed as micronutrients: iron (Fe), manganese (Mn), zinc (Zn), boron (B), copper (Cu), molybdenum (Mo), and cobalt (Co).

Various definitions relating to fertilizers are given in the European fertilizer regulation (EC) No. 2003/2003 (Ref 5).

### 3.2 TYPES OF PRODUCTS

Fertilizers currently marketed as EC Fertilizer are detailed in the European Regulation (EC) No. 2003/2003. Other products may be possible depending on national regulations. The main types of fertilizers currently marketed in Europe include:

- Ammonium nitrate (AN)
- Calcium ammonium nitrate (CAN)
- Urea
- Compound fertilizers (e.g. NP, NK, PK and NPK)

- Sulphate containing fertilizers such as ammonium sulphate (AS), ammonium sulphate nitrate (ASN) and mixtures of AN with calcium sulphate/magnesium sulphate/limestone/dolomite
- Phosphate fertilizers such as monoammonium phosphate (MAP), diammonium phosphate (DAP), single superphosphate (SSP) and triple superphosphate (TSP)
- Potassium containing fertilizers such as potassium nitrate (NOP), potassium chloride (MOP) and potassium sulphate (SOP).

To produce compound fertilizers with the required levels of nutrients, some of the above substances can be processed together to give complex granules/prills or can be physically mixed i.e. blended. A large number of compound fertilizers are produced from basic primary fertilizer products (e.g. ammonium nitrate, urea, and monoammonium phosphate) and natural materials (e.g. rock phosphate, potassium chloride).

All such materials are not necessarily compatible with each other; some may produce undesirable effects when mixed with others for producing blends. Careful selection of the source materials is required, for which guidance has been published by EFMA (Ref 6).

AN provides fertilizer nitrogen in two forms; quick acting nitrate and slower acting ammonium. Refer to the EFMA booklet, Understanding Nitrogen and its Use in Agriculture for comparative agronomic and environmental aspects of use of these fertilizers.

### 3.3 DEFINITIONS AND EXPLANATION OF TERMS

Definitions of the various terms and vocabulary commonly used in relation to fertilizers can be found in EN 12944 (3 parts) (Ref 7) and in the EU Fertilizer Regulation EC2003/2003 (Ref 5).

#### Additives

Chemical substances added to fertilizers in small quantities e.g. to facilitate manufacturing processes and/or to improve their agronomic values and/or quality parameters (e.g. caking tendencies, thermal stability).

Examples of additives include ammonium sulphate, magnesium nitrate, aluminium sulphate, and a variety of proprietary products.

#### Ammonium Nitrate (AN) Based Fertilizer

Fertilizers which contain nitrogen in both ammonium ( $\text{NH}_4^+$ ) and nitrate ( $\text{NO}_3^-$ ) forms, irrespective of their source.

#### Ammonium Nitrate (AN) Content

Amount of ammonium nitrate in a fertilizer, calculated on the basis of nitrate ions for which a molecular equivalent of ammonium ions is present.

Example 1:

The ammonium nitrate (AN) content of a fertilizer which contains 7% nitrate nitrogen and 12% ammoniacal nitrogen is calculated as follows:

Nitrate nitrogen content derived from ammonium nitrate = 7%.

Ammonium nitrate contains equal amount of nitrate N and ammoniacal N

Therefore ammoniacal N content = 7%

Therefore total N content derived from ammonium nitrate = 14%.

As pure ammonium nitrate (formula  $\text{NH}_4\text{NO}_3$ ) contains 35% total nitrogen, the ammonium nitrate content of this fertilizer is:

$$\frac{14 \times 100}{35} = 40\%$$



The following table gives the total nitrogen content in fertilizers **derived from AN**:

AN %	100	90	80	70	60	45	30
N %	35	31.5	28	24.5	21	15.75	10.5

Example 2:

The ammonium nitrate (AN) content of a fertilizer which is made of 60% potassium nitrate and 40% MAP can be calculated as follows:

Potassium nitrate contains no ammoniacal N and 13.86% nitrate N.

MAP contains, typically, 11% ammoniacal N and no nitrate N.

Therefore, the mixture contains:

nitrate N from potassium nitrate  $60 \times 13.86/100$  or 8.3%

ammoniacal N from MAP  $40 \times 11/100$  or 4.4%

The ammoniacal N is the limiting number because it is less than the nitrate N value. Therefore total N as derived from AN =  $2 \times 4.4 = 8.8\%$ .

Therefore, calculated equivalent ammonium nitrate content in the fertilizer =  $(8.8 / 35)$  or 25.14%.

### Blended Fertilizer

Fertilizer obtained by the dry mixing of several fertilizers, with no chemical reaction.

### Classified

Classified is used in this guidance to describe fertilizer products and related substances, which are classified as dangerous under the UN scheme for transport regulations, falling in classes such as oxidizer, class 5.1.

### Coating Agents/Materials

Additives applied to the surface of fertilizer particles to improve the quality parameters, such as moisture pick-up, caking tendency, dust formation and flowability.

### Combustible Material

“Combustible material” and “total combustible material” when used in legislation, both refer to the total amount of organic and inorganic combustible material (e.g. elemental sulphur) present in the product, expressed as carbon.

NOTE: All other references to combustible material used in this guidance apply to common materials such as petrol, diesel fuel, kerosene, paint, wood, organic waste, straw, grain, elemental sulphur, etc.

### Complex Fertilizer

Compound fertilizer, obtained by chemical reaction, by solution or, in its solid state, by granulation, having a declarable content of at least two of the primary nutrients.

NOTE: In its solid state each granule contains all the nutrients, approximately in their declared composition.

### Compound Fertilizer

Fertilizer having a declarable content of at least two of the primary nutrients and obtained chemically or by blending or by a combination of both.

### Critical Relative Humidity (CRH)

Value of the relative humidity of the surrounding air, above which the material absorbs moisture and below which it does not.

### Density (units kg/m<sup>3</sup>)

Density is expressed and measured in a number of different ways; the main types are given below:

- **Bulk density (loose)**  
Mass per unit volume of a material after it has been tipped freely into a container under clearly specified conditions [EN 12944-2] (Ref 7).
- **Bulk density (tapped)**  
Mass per unit volume of a material tipped into a container and compacted under clearly specified conditions [EN 12944-2] (Ref 7).
- **Material density**  
Mass per unit volume of the material included within the surface of the particles [EN 12944-2] (Ref 7).
- **Packing (also called loading) density**  
Mass per unit volume of a material after a tube has been filled with this material with intermittent tapping of the tube to compact the material e.g. in the EU resistance to detonation test (Ref 5).

### Dunnage

Something that is placed under the stacks to protect the fertilizer from moisture damage.

NOTE: Wooden pallets make ideal dunnage as they raise the bags and permit air circulation, which helps to remove moisture.

### Filler

Material which has no primary nutrient value, added mainly to adjust the final nutrient content of fertilizers to the required levels.

NOTE: Fillers include calcium carbonate, dolomite and calcium sulphate (gypsum, anhydrite). Some of these may contain secondary nutrients (e.g. S, Mg, Ca,) and/or have beneficial effects, e.g. on soil pH and on the thermal stability and detonation properties of ammonium nitrate.

### Inert Materials

Fillers or additives which do not affect the chemical properties of ammonium nitrate (such as e.g. clay and sand).

### Non-conforming Fertilizer Materials

Materials which do not meet the characteristics of the intended products at the time of production and/or storage (as relevant) or when marketing.

NOTE: They include both off-spec and reject materials, which are defined below. Essentially, they include everything other than marketable specified product.

- **Off-spec products**

Products that do not meet their specifications for chemical and physical characteristics.

NOTE: A number of chemical and physical characteristics are specified for fertilizers, for production and/or marketing purposes, generally related to quality and/or safety. They include, for example, nutrient contents; moisture level; particle size; pH; stabiliser content; presence of proscriptive concentrations of heavy metals, chloride and carbon; bulk density; oil retention (porosity); colour; caking tendency; besides detonability and capability in terms of self-sustaining decomposition.

During production, deviations in process controls can lead to products that do not meet one or more of these specifications. Changes can also take place during storage and subsequent handling, taking the product out of specification. These changes include, for example, moisture pick-up, physical breakdown, caking and contamination. Most of such deviations or changes have no significant impact on the potential hazards of the products; they tend to give rise to quality issues. In this guidance, these materials are described as off-spec products. Thus, it does not mean that the product is unsafe or non-saleable. It may be acceptable to sell it

as a fertilizer under a new specification or for a different application, or it may be possible to recycle or rework it within the process.

- **Reject materials**

Products which are out of specification, or have deteriorated during storage and/or handling in such a way that they can be considered potentially hazardous.

NOTE: They cannot be sold as fertilizer products and may require treatment to render them safe. Examples include; those which contain more than the maximum permitted level of combustible material; those which have physically degraded into fines and could fail the Resistance to Detonation Test, where applicable, and products grossly contaminated with reactive substances.

### **Nutrient Content**

The expression of the primary nutrient contents in the form of nitrogen as % N, phosphorus as % P<sub>2</sub>O<sub>5</sub> (or in some countries as % P) and potassium as % K<sub>2</sub>O (or in some countries as % K).

$$P_2O_5 \times 0.44 = P$$

$$K_2O \times 0.83 = K$$

$$SO_3 \times 0.40 = S$$

### **Stabilisers**

A particular group of additives which can be added to ammonium nitrate based fertilizers to improve their stability against deterioration due to fluctuations in temperature during storage and transport.

### **Straight Fertilizer**

A nitrogenous, phosphoric or potassic fertilizer having a declarable content of only one of the primary nutrients.

NOTE: In the UN transport regulations the description 'Nitrogen type' has been used for straight fertilizers.

### **Types A, B and C Fertilizers**

Descriptions which have been applied in the past based on the classification of the fertilizers.

Type A refers to oxidizers (Class 5.1); Type B was used for those capable of self-sustaining decomposition (Class 9) and Type C for those not classified as dangerous. In some countries (e.g. The Netherlands and Germany) this terminology is used but the definitions differ. These descriptions are not used in this guidance and the main categories are based on the UN classification system (see Chapter 7).

## **3.4 QUALITY AND SAMPLING ISSUES**

### **Quality**

Fertilizers are normally manufactured as high quality products in the form of prills or granules to enable effective spreading. In the handling and storage of fertilizers it is important to ensure that the quality is maintained right up to the point of usage: namely no moisture pick up, no caking, free from contamination and of minimal dust content.

It is important that blends do not segregate during storage, handling and transport to ensure uniform application of the nutrients. This also applies to micronutrient sources.

### **Sampling**

It is important to get a representative sample for analytical and quality purposes. Taking a sample from a moving stream is preferable to collecting from a heap or a bag. Further information is given in Ref 8. Appropriate guidance should be consulted.

## **3.5 BASIC PRINCIPLES**

The following underlying principles are given for the fulfilment of the objectives stated above in 1.1. These are in no particular order of priority.

- Prevent contamination by foreign matter of any kind but particularly: combustible matter, elemental sulphur, farm chemicals such as weed-killers, organic materials, oils and greases, acids and alkalis.
- Avoid mixing incompatible fertilizers for safety and/or quality reasons (e.g. AN and urea in solid state). For detailed information see EFMA guidance for the compatibility of blending materials (Ref 6).
- Avoid involvement in a fire.
- Store away from sources of heat and avoid heating.
- Observe fire precautions.
- Avoid the combination of heat and severe confinement.
- Store away from explosives.
- Do not use explosives to break up caked fertilizer.
- Avoid moisture uptake.
- Adhere to good housekeeping practices.
- Secure stores and associated vehicles against unauthorised access.
- Carry out audits and take corrective actions as necessary.

In the selection of storage sites, particular consideration should be given to:

- Compliance with any relevant national legislation.
- Proximity to potential sources of fire and explosion.
- Proximity to centres of population, hospitals, schools, etc.
- Risk of water pollution, for example of water courses and canals, by fire-fighting water.
- Risk of theft, unauthorised access and breach of security.

### 3.6 ACCIDENT REPORTING

Learning from each other's accidents plays an important part in efforts to improve safety. In recognition of this fact, EFMA has set up an accident reporting scheme for its members which encourages them to report their accidents to EFMA. The accident information is circulated to other members and the compiled data of reported accidents are analysed by EFMA to identify safer practices.

## 4. HISTORICAL PERSPECTIVE

AN is a valuable substance used in agriculture and in industrial applications. It is produced in different physical forms specifically suiting these applications, e.g. high density prills/granules as fertilizers, low density prills for explosives and AN solution for the manufacture of  $N_2O$ . Whereas it is used directly as a nitrogen fertilizer, for the explosives industry it is a raw material e.g. for producing ammonium nitrate – fuel oil mixtures (ANFO). The world production of fertilizer grade AN is close to 25 million tonnes annually. The world production for industrial grades of AN is in the region of 10 million tonnes per year.

Ammonium nitrate does not occur naturally in mineral form, it is produced chemically.

In the 1910-20 period, mixtures of AN with AS and with limestone were produced as commercial fertilizers. The AN/AS mixtures caked badly and explosives were used to break up heaps; this practice resulted in the Oppau tragedy (see Table 1). When World War II was over, the AN plants in the US which were producing it for ammunition purposes, started applying wax to the straight AN to prevent caking and selling the product for agricultural use; this practice contributed to the disastrous accident at Texas City in 1947, see Table 1 which also lists other high fatality accidents (Refs 9, 10). Following the Texas City accident, much research and development work was carried out to develop safe products.

**Table 1 Some high fatality accidents**

Date Location	Description
1921 Oppau, Germany	Caked AN-AS fertilizer detonated when blasting explosive was used to break it up. > 500 fatalities.
1942 Tessenderloo, Belgium	Use of blasting explosive led to a detonation in a pile of AN. > 100 fatalities
1947 Texas City, Texas, USA	Wax-coated AN cargo in two ships exploded following a major fire. > 600 fatalities.
1947 Brest, France	Wax-coated AN cargo in a ship exploded following a fire. 21 fatalities.
2001 Toulouse, France	A heap of non-conforming high and low density AN materials detonated, without prior fire or visible decomposition. 30 fatalities.
2004 Michailesti, Romania	A fire on a truck carrying bagged AN fertilizer was followed by an explosion. 19 fatalities.

The development of safe anti-caking treatment and prilling/granulation processes in the early fifties, coupled with clearer guidance for safe practices, helped to boost the large-scale production of high density AN as prills or granules for use as a nitrogen fertilizer. This product has high resistance to detonation and its safety record is very good. There has been no major explosion accident with the fertilizer grade product in storage in the last 50+ years. (The explosion accident, which happened in the store at Cherokee Nitrogen plant in the US in 1974, involved only a few tonnes of AN and there were no fatalities). However, there have been a few explosion accidents during transport in the recent years.

## 5. GENERAL PROPERTIES

In this chapter the physical and chemical properties of the main fertilizer materials are described. Data relating to all the properties (e.g. crystalline form, pH, hygroscopicity, thermal conductivity) are not given for each material as such data have not been readily available.

The main health and toxicity data are briefly presented in Chapter 6 and for more detailed information reference should be made to the producers' Material Safety Data Sheets.

### 5.1 AMMONIUM NITRATE (AN)

- Molecular formula  $\text{NH}_4\text{NO}_3$
- Molecular weight 80
- CAS number: 6484-52-2
- EINECS: 299-347-8
- Total N content 35%

Pure ammonium nitrate is a white crystalline solid with a melting point of 169.6°C. There is no true “boiling point” because decomposition begins to take place before the boiling condition is reached.

#### Crystalline Forms

AN occurs in five different stable crystalline forms or phases in the solid state. The main transitions are summarised in Table 2 (Ref 11). These transitions are accompanied by volume changes as shown in Figure 1. Of particular interest to the fertilizer industry is the transition at 32°C, which is accompanied by a substantial volume increase (approximately 3.6%) as the temperature is raised. In a storage situation if the temperature fluctuates across 32°C and the material goes through cycles of temperature changes, the resulting density changes can cause the product to break down into fines. (As a consequence the bulk density is likely to reduce and bags could swell up). To prevent this, certain stabilisers can be added e.g. magnesium nitrate, aluminium sulphate, which shift the transition to a higher temperature involving a smaller volume change, as can be seen in figure 1. This is referred to as thermal stabilisation (Refs 9, 11).

Table 2 Crystalline forms of AN

Form	Crystal system	Temperature range (°C)	Specific volume (cm <sup>3</sup> /g)	Density <sup>(1)</sup> (g/cm <sup>3</sup> )
Liquid	–	>169	0.697	1.435
Phase I	Cubic	169.6 to 125.2	0.642-0.627	1.563-1.595
Phase II	Tetragonal	125.2 to 84.2	0.612-0.603	1.634-1.658
Phase III	Rhombic	84.2 to 32.3	0.613-0.605	1.631-1.653
Phase IV	Rhombic	32.3 to -18	0.582-0.572	1.718-1.748
Phase V	Tetragonal	Below -18	0.589	1.698

<sup>(1)</sup> Density is the inverse of the specific volume.

Figure 1 Effect of temperature on density and crystalline forms of AN

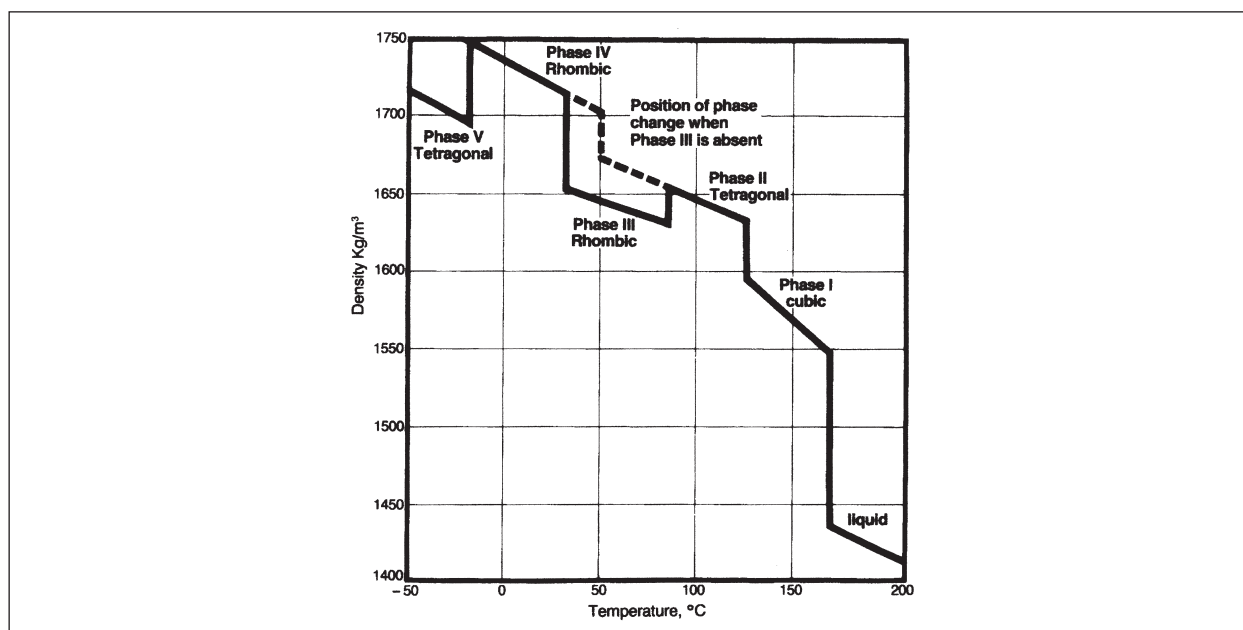

### Density

The material density of **solid AN (crystalline block)** is 1725 kg/m<sup>3</sup> at a room temperature.

As described in Section 3.3 the density of prills/granules can be measured and expressed in a number of different ways e.g. material, bulk (loose and tapped, Ref 7) and packing. In the EC test of resistance to detonation a procedure is described for filling the tube which involves tapping according to a described method. The bulk density thus measured is called *the packing density* in the relevant regulations (Ref 5). Care should be taken to specify the type and the method of determination when describing density,

Prilled or granular fertilizers have loose bulk densities typically in the range of 850 to 1100 kg/m<sup>3</sup>, which depend on the source materials and the manufacturing process used. Indicative values of bulk density for some of the main products based on AN are given below.

AN	0.85-1.0
CAN	0.90-1.05
AN+CaSO <sub>4</sub>	0.95-1.1
NPK	0.90-1.1

### Hygroscopicity and critical relative humidity

AN based fertilizers, like many other fertilizers, are hygroscopic and will therefore, tend to absorb moisture from the atmosphere (depending on the relative humidity, RH) if left exposed. This can cause product deterioration, which is seen as caking and/or dust formation.



The effects of temperature on CRH and corresponding water vapour content in air are summarised in table 3.

**Table 3 Influence of temperature on the CRH of ammonium nitrate**

Temperature, °C	10	15	20	25	30	40	50
% Critical relative humidity of AN	75.3	69.8	66.9	62.7	59.4	52.5	48.4
g H <sub>2</sub> O/kg dry air at the above temperature and relative humidity	6	7	10	13	16	25	41

The CRH of fertilizers based on ammonium nitrate is affected by other source materials, blending components and additives, which may be present. Relevant data are given in references 6, 11 and 12.

Changes in CRH when making blends are presented in reference 12.

### Solubility

AN is very soluble in water and heat is absorbed when it goes into solution, making it difficult to dissolve large quantities quickly in water. The solubility at different temperatures is given in the following table.

**Table 4 Solubility vs. T (Ref 10)**

Temp °C	20	40	60	80	100	120	140
Solubility g/100g water	194	274	405	609	1011	1786	3746
AN wt%	66.1	73.3	80.2	85.9	91.0	94.7	97.4

### Thermal conductivity

AN has a very low thermal conductivity, 0.000208 cal/sec.cm.°C (granular AN 33.5% 0.35% H<sub>2</sub>O density 0,965, measured at 18°C) (Ref 11); it can provide a good insulating effect. This is of significance in situations where frictional heat is generated (e.g. by a moving conveyor belt) in contact with heaps of AN or AN dust. This heat may not be readily dissipated and thus can lead to local heating, decomposition or burning of any combustible material present.

### Chemical properties

AN has oxidizing properties and, therefore, assists the combustion of combustible materials enabling them to burn even in the absence of air.

When heated it decomposes by way of a number of reactions. For further information see Section 6.1.

### pH

It is common industrial practice to express the pH of AN as that of a 10 wt% solution in water at 25°C. According to this practice the pH of a neutral AN solution is not 7, but is in the region of 4.5. Measuring the pH at different concentrations and/or temperatures will result in different values and these values need to be appropriately adjusted. The pH of AN fertilizer should be above the neutral point i.e. the product should not be acidic, as the acidic condition may give rise to very slow decomposition which may adversely affect the packaging.

## 5.2. AMMONIUM SULPHATE (AS)

- Molecular formula (NH<sub>4</sub>)<sub>2</sub>SO<sub>4</sub>
- Molecular weight 132
- CAS number: 7783-20-2
- EINECS: 231-984-1
- N-content 21% and S-content 24% (SO<sub>3</sub> 60%)

AS is an important source of sulphur in agriculture in addition to its nitrogen value.

The purity of commercial grades of ammonium sulphate depends on the production process. For example ammonium sulphate produced from coke-oven gas, from ammonia and sulphuric acid, from organic syntheses

(in particular from Caprolactam) and from gypsum, ammonia and carbon dioxide may show different levels and types of impurities. The water content is typically < 0.2% by weight.

Depending on the impurities present the crystals of ammonium sulphate can be white, colourless or grey-brown. Their typical sizes are: range 0.5 - 1.5 mm, 2 mm and 3 mm (larger sizes are mainly for bulk blending).

### Crystalline form

In the temperature range from -20 to +160°C ammonium sulphate exists in a single crystalline form and therefore does not show any phase transition.

The salt does not form hydrates.

### Density

The material density of ammonium sulphate is about 1770 kg/m<sup>3</sup> (at 20°C).

The loose bulk density is typically 1000 kg/m<sup>3</sup> (at 20°C), the range being 950-1050 kg/m<sup>3</sup>.

Loose bulk densities and mean particle sizes of three grades commercially available are as follows:

Crystalline      d<sub>50</sub>: 1.1 mm, density 1040 kg/m<sup>3</sup>

Granular        d<sub>50</sub>: 2.0 mm, density 1040 kg/m<sup>3</sup>

Granular        d<sub>50</sub>: 3.3 mm, density 1010 kg/m<sup>3</sup>

### Hygroscopicity

Although it is less hygroscopic than ammonium nitrate based substances, ammonium sulphate shows a tendency to cake, depending on various factors such as water content, initial storage temperature and the duration of storage. Ammonium sulphate crystals not used for further processing can be protected against caking by the application of small amounts (< 0.2%) of surfactants.

Ammonium sulphate can be stored in ambient air without absorbing moisture. However, it can pick up moisture from air above approximately 80% relative humidity at 30°C. This ability to absorb moisture increases significantly if small amounts of free sulphuric acid are present in the product.

### Solubility

The solubility as a function of temperature is given in the table below (Refs 13a, 13b, 13c). The dissolution is endothermic and a number of values for the heat of dissolution are given in Ref 13b for different conditions, all between + 6 and + 10 kJ/mol.

**Table 5 Solubility of ammonium sulphate**

Temp °C	10	20	40	60	80	100	125	150
Solubility g/100g water	72.7	75.4	81.2	87.4	94.1	103.3	113.7	124.7
AS wt%	42.1	43.0	44.8	46.6	48.5	50.8	53.2	55.5

### Chemical properties

The ammonia vapour pressure of pure anhydrous ammonium sulphate is negligible up to about 80°C. However, above 80°C and at lower temperatures in the presence of water, ammonia can be liberated. The pH-value of pure crystalline ammonium sulphate is about 5 at 100g/l and 20°C.

The melting point of ammonium sulphate is approximately 350°C, although decomposition begins at around 235°C, well below the above temperature (Ref 14).

Unless dry, ammonium sulphate is very corrosive in nature to both carbon steel and concrete. Due to the loss of ammonia, ammonium bisulphate is first formed and small amounts of free sulphuric acid may result, causing the corrosive effect. Stainless steel, wood or special alloys are preferred materials of construction.

Ammonium sulphate can be used as a straight nitrogen fertilizer and a component for producing blended or complex fertilizers.

### 5.3 UREA

- Molecular formula  $(\text{NH}_2)\text{CO}(\text{NH}_2)$
- Molecular weight 60
- CAS number: 57-13-6
- EINECS: 200-315-5
- N content 46.5%

Pure urea is a white crystalline solid with a melting point of about 133°C. There is no true “boiling point” because decomposition begins to take place before the boiling condition is reached. The odour is slightly ammoniacal.

#### Crystalline form

Urea has two crystal forms: needle and rhombic prism.

#### Density

The material density of urea (crystalline block) is 1333 kg/m<sup>3</sup> at room temperature.

Commercially available fertilizer products are in granular or prilled form which have loose bulk densities typically in the range of 700 to 800 kg/m<sup>3</sup>. The tapped bulk density is in the range of 820 to 950 kg/m<sup>3</sup>, depending on the size of the particles.

#### Hygroscopicity

Urea is hygroscopic. Its critical relative humidity is given in the table below (Ref 15).

**Table 6 CRH of urea**

Temp °C	10	15	20	25	30	40	50
CRH %	81.8	79.9	80.0	75.8	72.5	68.0	62.5

In order to prevent moisture pick-up, caking and/or dust formation urea fertilizer can be treated with conditioners either internally or externally.

#### Solubility

Urea is very soluble in water. Its solubility at different temperatures is given in the table below.

**Table 7 Solubility of urea**

Temp °C	0	20	40	60	80	100	110
Solubility g/100g water	67	105	163	246	396	725	1164
Urea wt%	40	51	62	71	80	88	92

#### Thermal conductivity

Urea has a very low thermal conductivity; it can provide a good insulating effect. The value for the crystals is 0.8J/s cm K gradient or 0.191 cal/sec cm °C gradient (Ref 16).

#### Chemical properties

Urea itself does not burn. On heating it decomposes giving off ammonia and carbon dioxide.

#### pH

The pH-value of an aqueous solution (100g/l) at 20°C is within the range 9 to 10.

### 5.4 POTASSIUM NITRATE

- Molecular formula  $\text{KNO}_3$
- Molecular weight 101
- CAS number: 7757-79-11
- EINECS: 231-818-8
- N content 13.86%,  $\text{K}_2\text{O}$  content 46.6%

Potassium nitrate is also known as Nitre or Saltpetre. In pure form it is a white crystalline solid with a melting point around 334°C. Its boiling point is estimated as 400°C but decomposition occurs before this temperature is reached.

#### Crystalline forms

Potassium nitrate crystallises from aqueous solutions in the form of colourless rhombic prisms and from acidic solutions in the form of rhombohedra. The rhombic form at normal temperatures is metastable and on heating to 128°C passes into a trigonal-rhombohedral form.

#### Density

The material density of solid KNO<sub>3</sub> is 2109 kg/m<sup>3</sup> at 16°C. Commercially this material is available in both granular and crystalline forms with a loose bulk density for each within the range 1100 – 1200 kg/m<sup>3</sup>.

#### Hygroscopicity

Potassium nitrate is not very hygroscopic; its CRH value is 90.5 at 30°C (Ref 12) and 92.3 at 20°C (Ref 11).

#### Solubility

Potassium nitrate is highly soluble in water. The solubility at various temperatures is given below (Ref 17).

**Table 8 Solubility of potassium nitrate**

Temp °C	0	20	40	60	80	100
Solubility g/100g water	13.3	31.6	63.9	110.0	169.0	246.0
wt%	11.7	24.0	39.0	52.4	62.8	71.1

#### Chemical properties

Potassium nitrate has a pH-value of approximately 7 at 25°C.

Potassium nitrate is an oxidant and reacts at high temperatures with combustible and reducing materials. It assists the combustion of combustible materials even in the absence of air. Above 400°C it decomposes and liberates oxides of nitrogen.

### 5.5 SODIUM NITRATE

- Molecular formula NaNO<sub>3</sub>
- Molecular weight 85
- CAS number: 7631-99-4
- EINECS: 231-554-3
- N content 16.47%, Na content 27%

#### Crystalline form

Sodium nitrate is a white crystalline solid

#### Density

The loose bulk density is 1300 kg/m<sup>3</sup>

#### Hygroscopicity

Sodium nitrate is hygroscopic

#### Solubility

The solubility is 87.4 g/100g water (46.6 wt %) at 20°C .

#### Chemical properties

The melting point is 307°C and the pH-value 8-9. Decomposition starts at temperatures above 600°C.

Sodium nitrate is an oxidizer.

## 5.6 CALCIUM NITRATE FERTILIZER

The following information applies to the fertilizer grade calcium nitrate which is essentially hydrated ammonium calcium nitrate double salt also known as Kalksalpeter (in certain countries) and as nitric acid, ammonium calcium salt.

- Molecular formula of the main component  $5\text{Ca}(\text{NO}_3)_2 \cdot \text{NH}_4\text{NO}_3 \cdot 10\text{H}_2\text{O}$
- Molecular weight of the main component: 1080
- CAS number: 15245-12-2
- EINECS: 239-289-5
- N content 15.5% , Ca content 18.8%

### Density

The loose bulk density is 1100 kg/m<sup>3</sup>.

### Hygroscopicity

The critical relative humidity is just below 40% at 25°C (Ref 18).

### Solubility

The solubility is in the region of 122 g/100g water at 20°C (Ref 19).

### Chemical properties

Calcium nitrate decomposes above 500°C and the thermal decomposition products are nitrogen oxides.

The product is incompatible with combustible material, alkalis and acids.

**Pure calcium nitrate**, also known as lime saltpeter or Norwegian saltpeter. (Chemical formula  $\text{Ca}(\text{NO}_3)_2$ , CAS no: 10124-37-5 and EINECS no: 233-332-1) is not normally traded as a fertilizer.

## 5.7 AMMONIUM PHOSPHATES: MAP AND DAP

Monoammonium phosphate (MAP)

- Molecular formula  $\text{NH}_4\text{H}_2\text{PO}_4$
- Molecular weight 115
- CAS number: 10124-31-9
- EINECS: 233-330-0
- N content 12.17% , P<sub>2</sub>O<sub>5</sub> 61.7% (in pure MAP)

Diammonium phosphate (DAP)

- Molecular formula  $(\text{NH}_4)_2\text{HPO}_4$
- Molecular weight 132
- CAS number: 7783-28-0
- EINECS: 231-987-8
- N content 21.19% , P<sub>2</sub>O<sub>5</sub> 53.76%

Ammonium phosphates in pure form are white crystalline solids of which MAP and DAP are of main interest. They are produced by the ammoniation of wet-process phosphoric acid and are mainly in the form of grey/brown or light green granules, the purity and colour of which depend on the phosphoric acid/phosphate rock source used. Phosphate rock is a naturally occurring mineral and, therefore, contains other components such as salts of iron, aluminium, magnesium and fluorine.

### Crystalline forms

Pure MAP crystals are of tetrahedral shape whereas DAP crystals are monoclinic.

### Physical properties

The main physical properties are summarised in the table below. The values are for the pure substance whereas those in brackets are typical values for commercial products.

**Table 9 Properties of MAP and DAP**

	MAP	DAP
Molecular weight	115	132
% Nitrogen	12.17 (11)	21.19 (18)
% P <sub>2</sub> O <sub>5</sub>	61.7 (52)	53.76 (46)
Material density kg/m <sup>3</sup> at 25°C	1803	1619
Loose bulk density kg/m <sup>3</sup>	(900-1000)	(900-1000)
pH (0.1 molar solution)	4.4	7.8
Melting point °C	190, decomposes	Decomposes
Vapour pressure at 125°C	0.05 mm	28.8 mm Hg
Solubility g/100g water		
At 0°C	22.7	42.9
20°C	32.8	58.8

**Solubility**

Both MAP and DAP are soluble in water; their solubilities at 0°C and 20°C are given in Table 9.

**Hygroscopicity**

At normal storage temperatures both MAP and DAP show very low hygroscopicity and caking tendency.

**Chemical properties**

MAP and DAP may liberate ammonia gas when in contact with strongly alkaline materials (Ref 20). When heated, DAP dissociates into ammonia gas and MAP.

MAP is the more stable of the two substances with negligible dissociation below 100°C. The ammonia vapour pressure of the two salts increases with temperature. Vapour pressure values at 125°C are given in the table above.

When heated, above its melting point, MAP decomposes into ammonia and phosphoric acid. On further heating it gives off nitrogen oxides and phosphorus oxides.

**5.8 SUPERPHOSPHATES****Single superphosphate (SSP)**

- Molecular formulae: the major constituents are monocalcium phosphate (Ca(H<sub>2</sub>PO<sub>4</sub>)<sub>2</sub>·H<sub>2</sub>O) and gypsum (CaSO<sub>4</sub>·2H<sub>2</sub>O)
- Molecular weights Ca(H<sub>2</sub>PO<sub>4</sub>)<sub>2</sub>·H<sub>2</sub>O: 252 and CaSO<sub>4</sub>·2H<sub>2</sub>O: 170
- CAS number: 8011-76-5
- EINECS: 232-379-5
- P<sub>2</sub>O<sub>5</sub> in the region of 20%

**Triple superphosphate (TSP)**

- Molecular formulae: the main constituents are monocalcium phosphate (Ca(H<sub>2</sub>PO<sub>4</sub>)<sub>2</sub>·H<sub>2</sub>O) and phosphoric acid (H<sub>3</sub>PO<sub>4</sub>)
- Molecular weights Ca(H<sub>2</sub>PO<sub>4</sub>)<sub>2</sub>·H<sub>2</sub>O: 252 and H<sub>3</sub>PO<sub>4</sub>: 98
- CAS Number: 65996-95-4
- EINECS: 266-030-3
- P<sub>2</sub>O<sub>5</sub> in the region of 46%

Both single and triple superphosphates are used mainly as fertilizer materials.

Both products may contain free acid and therefore can be corrosive.

## 5.9 MOP (SEE ALSO TABLE BELOW)

Muriate of Potash is basically potassium chloride, KCl for which data are given below.

- Molecular formula KCl
- Molecular weight 74.55
- CAS number: 7447-40-7
- EINECS: 231-211-8
- K<sub>2</sub>O 63%

### Density

The material density is 1984 kg/m<sup>3</sup>

### Hygroscopicity

The typical CRH for fertilizer grade tends to be in the range 50-70% at 25°C.

### Solubility

The solubility is 34.2 g/100g water at 20°C

### Chemical properties

Potassium chloride has a melting point of 771°C and a boiling point of 1407°C.

## 5.10 SOP (SEE ALSO TABLE BELOW)

Sulphate of Potash is basically potassium sulphate for which data are given below.

- Molecular formula K<sub>2</sub>SO<sub>4</sub>
- Molecular weight 174.26
- CAS number: 7778-80-5
- EINECS: 231-915-5
- K<sub>2</sub>O 54% and SO<sub>3</sub> 46%

### Density

The material density is 2660 kg/m<sup>3</sup>

### Hygroscopicity

The typical CRH for fertilizer grade tends to be in the range 60-80% at 25°C.

### Solubility

The solubility is 11.1 g/100g water at 20°C

### Chemical properties

Potassium sulphate has a melting point of 1069°C.

## 5.11 KIESERITE (SEE ALSO TABLE BELOW)

Magnesium sulphate exists in different hydrated forms e.g.:

Magnesium sulphate (calcined): MgSO<sub>4</sub>

Kieserite (monohydrate): MgSO<sub>4</sub>.H<sub>2</sub>O

Epsom salt (heptahydrate): MgSO<sub>4</sub>.7 H<sub>2</sub>O

The following information is for **kieserite** (Ref 21).

- Molecular formula MgSO<sub>4</sub>.H<sub>2</sub>O
- Molecular weight 138.38
- CAS number: 14168-73-1
- EINECS: 213-298-2
- MgO 27% and SO<sub>3</sub> 57.8%

**Density**

The material density is 2570 kg/m<sup>3</sup>, the loose bulk density is in the region of 1380 kg/m<sup>3</sup>.

**Hygroscopicity**

The typical CRH for fertilizer grade tends to be in the region of 50% at 25°C.

**Solubility**

The solubility is 34 g/100g water at 20°C.

**Chemical properties**

At 400-500°C it undergoes dehydration and at 700°C decomposes into MgO, SO<sub>2</sub> and O<sub>2</sub>.

**Table 10 Properties of MOP, SOP and kieserite**

	MOP	SOP	Kieserite
Name	Muriate of Potash, Potassium Chloride	Sulphate of Potash, Potassium Sulphate	Magnesium sulphate Monohydrate
Formula	KCl	K <sub>2</sub> SO <sub>4</sub>	MgSO <sub>4</sub> · H <sub>2</sub> O
Mol weight (g/mol)	74.55	174.26	138.38
Use	Potash fertilizer	Potash and sulphur fertilizer	Magnesium and sulphur fertilizer
Typical nutrient content “water-soluble”	60% K <sub>2</sub> O	50% K <sub>2</sub> O 18% S	27% MgO 22% S
Solubility in water at 20°C (wt% salt)	25	10	25 (c MgSO <sub>4</sub> )
Typical CRH * at 25°C * for fertilizer grade depending on producer	50–70%	60–80%	50%
pH (typical for 1% solution)	7	7	7
Material density (g/cm <sup>3</sup> )	1.99	2.66	2.57
Melting point	771°C	1069°C	At 400-500°C dehydration, at 700°C decomposition to MgO, SO <sub>2</sub> and O <sub>2</sub>

**5.12 CALCIUM SULPHATE**

Calcium sulphate (CaSO<sub>4</sub>) can exist in three main forms depending on the amount of crystal water present in the molecular structure:

anhydrite (no crystal water):	CaSO <sub>4</sub>	CAS number 7778-18-9
hemihydrate:	CaSO <sub>4</sub> ·1/2 H <sub>2</sub> O	CAS number 10034-76-1
dihydrate (gypsum):	CaSO <sub>4</sub> ·2 H <sub>2</sub> O	CAS number 10101-41-4

Calcium sulphate with no crystal water is called **anhydrite**, for which data are given below.

- Molecular formula CaSO<sub>4</sub>
- Molecular weight 136
- CAS number: 7778-18-9
- EINECS: 231-900-3
- SO<sub>3</sub> content 58.8%



### Crystalline forms

The anhydrite and dihydrate forms occur naturally in geological formations. The hemihydrate and the dihydrate are well-known by-products from phosphoric acid production. The dihydrate is also produced in chemical processes such as off-gas desulphurisation.

### Density

The material densities are:

Anhydrite: 2960 kg/m<sup>3</sup>

Hemihydrate: 2740 kg/m<sup>3</sup>

Dihydrate: 2320 kg/m<sup>3</sup>

Note: The material density may vary according to the origin and crystal form.

### Solubility

The solubility is in the region of 0.2 g/100g water at 20°C.

### Chemical properties

CaSO<sub>4</sub> is very stable and relatively unreactive. When heated to very high temperatures it decomposes releasing SO<sub>2</sub>.

## 5.13 DOLOMITE AND LIMESTONE

### Dolomite

Dolomite exists predominantly as calcium magnesium carbonate.

- Molecular formula CaMg(CO<sub>3</sub>)<sub>2</sub>
- Molecular weight 183
- CAS number: 16389-88-1
- EINECS: 240-440-2
- MgO 21.3% and CaO 30.6%

### Limestone

Limestone exists predominantly as calcium carbonate.

- Molecular formula CaCO<sub>3</sub>
- Molecular weight 100
- CAS Number: 1317-65-3
- EINECS: 215-279-6
- CaO 56%

### Density (bulk)

Dolomite: 1400-1600 kg/m<sup>3</sup>

Limestone: 900-1900 kg/m<sup>3</sup>

### pH

At 25°C, dolomite: 9.5-9.8 and limestone: 9.4.

### Solubility

Both are only sparingly soluble in water.

At 20°C, dolomite: 0.03% and limestone: 0.001%

Dolomite and limestone are found in geological deposits. Both substances are chemically stable and decompose only at elevated temperatures (>600°C) forming magnesium and/or calcium oxides.

## 6. HAZARDOUS PROPERTIES

Information relating to health, environment and safety can be found in the Safety Data Sheets (SDS), also referred to as Material Safety Data Sheets (MSDS).

Environmental data for the materials described above are given in Chapter 17.

It is important to note that all fertilizer materials described in Chapter 5 are themselves non-combustible.

### 6.1 AMMONIUM NITRATE BASED FERTILIZERS

#### 6.1.1 Overview

All ammonium nitrate based fertilizers, under normal conditions, are stable materials, which in themselves present no risk. Under abnormal conditions they can give rise to certain hazards; the most important of which are the enhancement of fire, thermal decomposition (with release of toxic fumes) and, under extreme conditions, explosion. These potential hazards are discussed below.

Useful references for further reading are 8, 22, 23 and 24.

#### 6.1.2 Fire Hazard

**AN-based fertilizers are not combustible.** Although not all AN-based fertilizers are classified as oxidizers, they are oxidizing in nature and, therefore, the risk of fire depends on other general combustible materials, which may be present, such as parts of handling equipment, the fuels, lubricants and hydraulic fluids used therein and materials stored or used in the construction of the store or bays. Experience shows that fires start in combustible materials inappropriately stored near the fertilizer or in associated equipment such as trucks or belt conveyors.

When a fire involves bagged fertilizer, the bags may melt and break but they will have an insignificant effect on the fire. Polyethylene (polythene) and similar packaging materials do not spread the burning; but may be oxidized by the hot or molten fertilizer. Hot spilled fertilizer may cause wooden pallets which are in contact with it to smoulder or burn. Pallets can allow heat and flames to penetrate into the interior of the stack.

With bulk fertilizer there are no packaging materials or pallets involved and the fire will not penetrate into the heap. The effect on the fertilizer depends on the fierceness of the fire and the other materials present.

The capability to intensify fire depends not only on the AN content of the fertilizer but also on the nature of the other components which may be present in the fertilizer and which may have a catalytic or thermal effect on the decomposition of AN.

### 6.1.3 Decomposition

#### Straight Ammonium Nitrate

Ammonium nitrate decomposes when heated to well above its melting point releasing water vapour, ammonia, nitric acid vapour and oxides of nitrogen by way of a number of reactions. These include (i) the endothermic and vapour-pressure-dependent reversible dissociation reaction into ammonia and nitric acid vapours and (ii) a number of exothermic reactions which are irreversible and release gases containing water vapour, toxic oxides of nitrogen and/or nitrogen. The combined effect of these endothermic and exothermic reactions produces a self-limiting thermal effect up to a certain temperature, provided the gaseous products are able to escape freely. This phenomenon has been theoretically studied and experimentally verified; it shows that under adiabatic conditions and free escape of gases the self-limiting temperature in pure AN is in the region of 290°C at atmospheric pressure (Ref 25). It must be emphasised that any adverse condition such as the presence of reactive or catalytic substances and/or confinement of product gases will reduce this temperature, making AN thermally less stable. Under extreme conditions, if the gases are not able to escape, the endothermic effect can be almost totally suppressed, leading to a rapid exothermic effect and explosive behaviour. This is of particular significance for hot work on equipment which has been used for handling or processing AN and which may still contain deposits of AN due to inadequate cleaning and/or inspection.

Certain substances, notably chlorides, copper and zinc, enhance the rate of decomposition in AN. Acid conditions also have a similar effect. AN reacts with many organic and combustible substances in exothermic ways, with the evolution of the above mentioned gases and fumes.

#### AN-based Compound Fertilizers

AN-based fertilizers are thermally stable and are not prone to self-heat dangerously in normal conditions of storage. They require an input of external heat to initiate decomposition. Consideration of the potential decomposition hazard is important for AN-based compound fertilizers which contain chloride e.g. in the form of MOP.

During the decomposition of compound fertilizers, e.g. caused by heating, copious amounts of fumes are given off which contain water vapour and various toxic gases such as oxides of nitrogen, hydrogen chloride, ammonia and chlorine depending on the composition of the fertilizer. The fumes may also contain ammonium chloride and ammonium nitrate which, along with the water vapour, can markedly reduce visibility. The decomposition is also accompanied by the release of heat with temperatures in the decomposing mass sometimes reaching 300-500°C. Decomposition can start when the fertilizer is in the solid state. Melting may also occur with fertilizers containing high levels of ammonium nitrate.

In many cases the decomposition, initiated by an external heat source, will stop when the source is removed. With some fertilizers, however, the decomposition will continue and spread deep into the mass of material even when the heat source is removed. This is the phenomenon of self-sustaining decomposition, sometimes referred to as 'cigar burning' where the decomposition propagates through the mass of the material (Refs 22, 23 and 24).

In the case of a self-sustaining decomposition its characteristics, e.g. speed of propagation, temperature in the decomposition zone and amount of gas produced, depend on the composition of the fertilizer and on the extent of melting at the decomposition temperature. The presence of compounds of trace elements such as copper and impurities such as chromium can increase this decomposition.

The speed of propagation can be measured by an official test, known as the Trough test (Ref 26).

With this type of fertilizer the bulk form of handling presents a greater risk than does packaged handling due to the relatively low threshold for initiation from exposure to heat sources and the ability to propagate the decomposition throughout the heap. Minor heat sources such as a buried inspection lamp or self-heating resulting from contamination, can be sufficient for the initiation of the decomposition.

Ammonia gas can be liberated from ammonium nitrate based fertilizers (as from all ammonium salts) when they come into contact with alkaline materials such as lime. Ammonia is a toxic gas; it is colourless but its presence can be detected by its characteristic strong smell.

#### 6.1.4 Explosion Hazard

Ammonium nitrate based fertilizer is difficult to detonate, as it is produced to have high resistance to detonation and thus requires very energetic shocks. Neither flame, nor spark, nor friction can cause detonation.

AN-based fertilizers, which pass the resistance to detonation test, have very high resistance to detonation. If not properly handled, a number of factors can decrease this resistance. These include contamination with incompatible substances, reduced particle size, increase in temperature and thermal cycling (which increases the porosity and causes breakdown of the prill or granule structure). In practice, the products contain additives to give good anti-caking properties and thermal stability. Adherence to good practice as given in this guidance minimises the risk of contamination and degradation.

The two main mechanisms which, in theory, can cause a detonation in an ammonium nitrate fertilizer stack or bulk heap are:

(i) Thermal decomposition: The development of rapid decomposition (deflagration) in a fire and its transition to detonation.

In a fire the transition of any rapid decomposition (deflagration) to detonation in a stack or bulk heap is very unlikely, because the necessary severe conditions of increased pressure i.e. confinement, are not met in practice. The risk is increased if the molten material is contaminated.

(ii) Shock initiation: A shock produced by an adjacent high energy explosion can initiate a detonation in the fertilizer. Initiation by impact from a high velocity projectile is more difficult; the fertilizer would need to be at higher temperatures, molten or contaminated.

Under normal conditions of production, storage and transport a high energy explosion adjacent to the fertilizer is extremely unlikely to occur in any credible industrial accident.

High velocity projectiles can be generated in a fire when ammonium nitrate based fertilizer is confined in hollow sections of equipment such as conveyor rollers and components of shovels. The rupture of welding equipment such as gas cylinders can have a similar effect. These projectiles would not have sufficient energy to initiate a detonation in normal solid products but molten and/or contaminated fertilizers would be more susceptible. Roof beams or building structures which may collapse in a severe fire do not have sufficient impact energy to initiate a detonation even in molten decomposing fertilizer. Initiation by impact of falling objects and projectiles has been investigated (Refs 27, 28).

When heated strongly under confined conditions, for example, in a fire, AN-based fertilizers can decompose violently causing an explosion. This can also occur during maintenance operations involving hot work on equipment in which fertilizer is confined (e.g. in a hollow section). Contamination of the fertilizer with combustible and other reactive substances increases this risk.

#### 6.1.5 Self-heating

The presence of combustible material (as a fertilizer component or contaminant) in ammonium nitrate fertilizers can, when the mixture is acidic, induce a slow spontaneous heating reaction. This results from the slow oxidation of the combustible materials. In the majority of cases this heating is only slight, but if the initial temperature of the fertilizer is abnormally high, the heating can lead to the thermal decomposition of the fertilizer and the evolution of toxic gases.

Reactions between components of the fertilizer during storage can also be a cause of self-heating. The extent of such heating is low, seldom exceeding 10°C, and normally presents no hazard.

#### 6.1.6 Dust

Mixtures of ammonium nitrate dust and air do not present a dust explosion hazard because ammonium nitrate is not combustible (Ref 29).

Accumulated deposits of contaminated dust, particularly with organic materials can present decomposition and fire hazards.

### 6.1.7 Product Breakdown

Fertilizers containing ammonium nitrate are generally manufactured in a prilled or granular form which enhances their quality and safety. In some formulations, the inclusion of materials such as dolomite or calcium carbonate suppresses acidity. In many cases additives are incorporated to prevent the disintegration of the product that could otherwise occur when the temperature is cycled through 32°C. This disintegration is caused by the significant increase in volume of the particles associated with the crystal structure change that occurs at about 32°C in products without such additives (see 5.1).

When stored in direct sunlight or under conditions where fluctuations between high and low temperatures can occur, these fertilizers may swell and physically break down particularly if they are inadequately stabilised or have picked up moisture. The effect is usually restricted to the surface layers of the product whether it is in bags or in bulk and results in material of unacceptable quality. In some cases with packaged material it can also result in damage to the bags.

### 6.1.8 AN Melt

AN melt can be generated in a fire involving solid AN and is potentially dangerous because of its high temperature and because it attacks the skin on account of its oxidizing properties.

Hot material will cause thermal and chemical burns to the skin. Most of the chemical properties and hazards described for solid material apply to these materials. More detailed information is given in a separate guidance produced by EFMA (Ref 30).

### 6.1.9 Toxic Fumes

Thermally decomposing straight AN fertilizer containing mainly AN and inert substances gives off gases which contain predominantly nitrous oxide (N<sub>2</sub>O) and water vapour. NO<sub>x</sub> gases are also given off in small concentrations, which depend on various factors. NO<sub>2</sub> is of main interest, from the standpoint of toxic hazards and this is discussed in 17.1.

Thermal decomposition of ammonium nitrate based compound fertilizers releases a mixture of gases such as water vapour, nitrogen, nitrous oxide, nitric oxide and ammonia, chlorine and hydrogen chloride, whose concentrations depend very much on the fertilizer composition (Refs 23, 24).

Perbal (Ref 23) gives the following indicative volumetric composition for fumes from an NPK formulation.

Water vapour	45-65%
Nitrogen	19-26%
Nitrous oxide (N <sub>2</sub> O)	7-20%
Hydrogen chloride	0.5-10%
Oxides of nitrogen (NO <sub>x</sub> (i.e. NO + NO <sub>2</sub> ))	0-9%
Ammonium chloride	0-7%
Chlorine	0-2%

Kiiski (Ref 24) gives the following average volumetric composition:

Water vapour, (H <sub>2</sub> O)	56%
Nitrogen gas, (N <sub>2</sub> )	20%
Nitrous oxide, (N <sub>2</sub> O)	11%
Chlorine and hydrogen chloride, (Cl <sub>2</sub> & HCl)	6%
NO, NO <sub>2</sub> , NH <sub>3</sub> , HF	7%

Oxides of nitrogen (variously known as nitrous fumes, NO<sub>x</sub>, and nitrogen oxides) are particularly toxic and the effects of their inhalation may be delayed and lead to pulmonary oedema (fluid in the lung).

## 6.2 AMMONIUM SULPHATE

No specific dangers of ammonium sulphate are known. As a general advice, contaminated clothing should be removed. Particle filters against dust may be used for respiratory protection. Ammonium sulphate is non-toxic on single ingestion or single skin contact; it is non irritant to skin and eyes and is not mutagenic.

Ammonium sulphate is not combustible but when heated at temperatures of 235°C and above, ammonia can be emitted.

Ammonium sulphate is neither detonable nor flammable and is not classified as a hazardous material. Mixtures of ammonium sulphate with ammonium nitrate containing more than 45% ammonium nitrate are classified as oxidizers (UN number 2067), see Chapter 7.

## 6.3 UREA

Urea is non-toxic on single ingestion or single skin contact but is irritant to skin and eyes. Particle filters against dust may be used for respiratory protection. It should be noted that biuret which may be formed in the manufacture of urea is agronomically undesirable. Its maximum level is specified in regulations.

Mixtures of solid urea and AN have low melting points and high hygroscopicity, making physical handling difficult. Molten urea can increase the detonation sensitivity of AN. Therefore, their mixing should be avoided.

Molten urea, which may be formed in hot maintenance work or in a fire, is potentially dangerous because of the possibility of the release of ammonia, its high temperature and because it can attack the skin. Hot material will cause thermal burns of the skin.

Urea itself does not burn. Thermal decomposition of urea fertilizers takes place at temperatures above 133°C, releasing toxic ammonia gas. Heating under strong confinement can lead to pressure build-up and physical rupture of the container.

Urea dust does not give rise to a dust explosion hazard (Ref 31).

Mixing of urea with nitric acid should be prevented to avoid the risk of the formation of urea nitrate which has explosive properties.

Urea is not classified as a hazardous material according to the Directive 67/548/EEC and the UN transport regulations; it is neither detonable nor flammable.

## 6.4 POTASSIUM NITRATE

When heated above 350°C, e.g. on contact with hot surfaces or in a fire, potassium nitrate decomposes forming oxides of nitrogen (variously known as nitrous fumes, NO<sub>x</sub>, and nitrogen oxides) which are particularly toxic.

Potassium nitrate has oxidizing properties and therefore can react with combustible and organic materials.

Potassium nitrate is classified as an oxidizer, Class 5.1 with UN number 1486.

## 6.5 SODIUM NITRATE

Sodium nitrate decomposes when heated above 380°C releasing nitrogen and oxides of nitrogen (variously known as nitrous fumes, NO<sub>x</sub> and nitrogen oxides), which are particularly toxic.

Being an oxidizer sodium nitrate can react with combustible and organic materials.

Sodium nitrate is classified as an oxidizer, Class 5.1 with UN number 1498.

## 6.6 CALCIUM NITRATE FERTILIZER

Calcium nitrate decomposes when heated above 500°C releasing nitrogen and oxides of nitrogen (variously known as nitrous fumes, NO<sub>x</sub> and nitrogen oxides), which are particularly toxic.

## 6.7 AMMONIUM PHOSPHATES (MAP AND DAP)

### Monoammonium phosphate (MAP)

When heated to decomposition (above 190°C) MAP emits toxic products such as fluorides, phosphorus oxides, ammonia and nitrogen oxides (Ref 32).

### Diammonium phosphate (DAP)

DAP melts and decomposes at 155°C to form MAP and ammonia. It will however, liberate ammonia at lower temperatures above 100°C. At elevated temperatures e.g. in case of a fire, it can decompose releasing nitrogen oxides, phosphorus oxides and fluorides.

Neither compound is flammable, nor do they exhibit explosive or oxidizing properties.

## 6.8 SUPERPHOSPHATES (SSP AND TSP)

When heated severely e.g. in a fire, SSP can give off toxic phosphorus oxides and sulphur oxides.

Involvement of TSP in a fire (>982°C) may lead to some decomposition. Inhalation of the decomposition gases, containing toxic fluorides and oxides of sulphur and phosphorus, can cause irritation and corrosive effects on the respiratory system. Some lung effects may be delayed.

## 6.9 MOP

MOP is not combustible. When heated strongly it can release hydrogen chloride (HCl) fumes.

## 6.10 SOP (SULPHATE OF POTASH)

SOP is not combustible. When heated strongly it can release sulphur oxides (SO<sub>x</sub>).

## 6.11 CALCIUM SULPHATES

CaSO<sub>4</sub> is very stable and relatively unreactive. Only when heated to very high temperatures will it decompose releasing toxic sulphur oxides (SO<sub>x</sub>).

## 6.12 KIESERITE

Magnesium sulphate decomposes when heated strongly (above 700°C) releasing fumes containing MgO, SO<sub>2</sub> and O<sub>2</sub>.

## 6.13 DOLOMITE AND LIMESTONE

Dolomite and limestone are not combustible. When heated at temperatures above 600°C, they can release carbon dioxide (CO<sub>2</sub>).

## 7. CLASSIFICATION

### 7.1 GENERAL

Most of the fertilizer substances/preparations are not classified as dangerous in current relevant regulations. However, certain nitrate-containing fertilizers are classified as dangerous (hazardous). It is important to bear in mind that even those fertilizers, which are not classified, may be capable of presenting hazards. It is, therefore, prudent and good practice to take account of the potentially hazardous properties and take appropriate precautions even when not classified.

A number of descriptions in regulations stipulate fertilizers to be 'uniform'. "Uniform" means that the component parts of the mixture should not segregate during handling, to such an extent that a significant volume of the mixture no longer complies with the classification.

**Fertilizer-grade AN is not classified as an explosive under the UN scheme of classification.**

In the European Union, substances are classified for two purposes:

- **supply** to customers, with a view to providing safety and risk information on the packages by means of labels and by means of safety data sheets. This is described in the CPL Directive (Ref 33).
- **transport**: this is regulated by a United Nations' Committee.

**Storage** is controlled by national regulations.

At present these classification systems do not have identical tests and criteria and it has been agreed at the international level to harmonise these and other similar schemes into a Globally Harmonized System (Ref 34). For oxidizers (e.g. AN) the UN transport scheme will be adopted in the GHS for classification. The new system is expected to come into effect around 2008.

According to the UN Recommendations on the Transport of Dangerous Goods (Ref 35), solid fertilizer products are divided into three categories:

- Oxidizers, Class and Division 5.1
- Miscellaneous, Class 9
- Not classified as hazardous



It should be noted that micronutrients can present potential toxic hazards. If added, the products should be checked for the relevant classification e.g. marine pollutant, toxic, harmful etc.

## 7.2 SUPPLY RELATED CLASSIFICATION

The oxidizing capacity test, A17, which is used in the EU's CPL Directive to classify substances as oxidizers is somewhat different from the UN test and therefore can give different results.

Most fertilizer nitrates are not classified as oxidizers under CPL e.g. potassium nitrate, sodium nitrate, ammonium nitrate and calcium nitrate.

## 7.3 CLASS 5.1, OXIDIZERS (AS PER UN CLASSIFICATION)

### 7.3.1 Ammonium nitrate based fertilizers, UN 2067

These fertilizers are classified as oxidizing, because they can assist the combustion of other materials. This classification is based on compositions and past experience, as the UN classification tests (Ref 26) tend to give inconsistent results with these products. The details of the compositions are defined in the special provision number 307, which is given in Appendix 1, along with a table of the types of AN-based fertilizers covered by UN 2067 and UN 2071.

It should be noted that the relevant UN body has approved a proposal at its December 2006 session to amend special provision 307 b) so as to permit the inclusion of  $\text{CaSO}_4$  of mineral origin to replace limestone/dolomite completely or partly. This will be implemented in 2008-9.

### 7.3.2 Other nitrate-containing fertilizers

– potassium nitrate	oxidizer 5.1	UN 1486
– magnesium nitrate	oxidizer 5.1	UN 1474
– sodium nitrate	oxidizer 5.1	UN 1498
– calcium nitrate	oxidizer 5.1	UN 1454, Special Provision 208

Special Provision 208: “The commercial grade of calcium nitrate fertilizer, when consisting mainly of a double salt (calcium nitrate and ammonium nitrate) containing not more than 10% ammonium nitrate and at least 12% water of crystallisation, is considered non-dangerous.”

Note: Nitrates, not otherwise specified, UN 1477. This is not recommended for fertilizers. Only use in exceptional circumstances in consultation with the competent authorities.

## 7.4 SELF-SUSTAINING DECOMPOSITION (SSD) TYPE, CLASS 9, MISCELLANEOUS

### Ammonium nitrate based fertilizer, capable of self-sustaining decomposition (SSD), UN 2071

The main hazardous property of a Class 9 fertilizer is the ability to undergo self-sustaining decomposition; this is assessed by the UN ‘Trough Test’ (see Section 6.1.3).

Fertilizers in this category are uniform mixtures of AN-based NPK/NK fertilizers with not more than 70% AN and not more than 0.4% of total combustible/organic material, or with not more than 45% of AN with unrestricted combustible material and which are shown to be capable of SSD in the official Trough Test (Ref 26). Special provision 193 is given in Appendix 1.

## 7.5 NOT CLASSIFIED AS HAZARDOUS

Common fertilizers not containing nitrate (see 3.2) are not classified.

Also, those AN-based fertilizers not covered by UN 2067 and UN 2071 belong to this category. Thus they would include, in the main:

- Mixtures of ammonium nitrate with calcium carbonate and/or dolomite containing not more than 80% of ammonium nitrate and not more than 0.4% total combustible material.
- Mixtures of ammonium nitrate/ammonium sulphate containing not more than 45% ammonium nitrate and not more than 0.4% of total combustible material.

- Fertilizers conforming to the UN 2071 composition, but which do not exhibit the property of self-sustaining decomposition.

Although these fertilizers are not classified as dangerous, they should not be considered as totally free from hazards and appropriate precautions should be taken.

## 8. LEGISLATION

### 8.1 FERTILIZER REGULATION, EC 2003/2003 (REF 5)

This is the most important legislation concerning the trading and marketing of fertilizers in the EU and covers several important aspects such as permitted materials, nutrient declaration, tolerances, labelling, handling, safety criteria and tracing etc.

### 8.2 SEVESO II DIRECTIVE, 2003/105/EC (REF 36)

This is the most important major accident hazard legislation in the EU.

It covers AN-based products, potassium nitrate, other oxidizers and many other substances. Ammonium nitrate products/materials are listed in four different categories and potassium nitrate in two categories. The definitions of these categories and the thresholds applicable are given in Appendix 2.

There are two levels of controls proposed in the legislation corresponding to two different thresholds of quantities present. Various requirements are specified such as the preparation and submission of a detailed safety report, the provision of emergency plans, and the provision of information to the public etc.

The thresholds do not represent maximum limits for storage but represent different levels of controls and requirements.

National Regulations adopting the Directive may be stricter in some countries.

### 8.3 TRANSPORT

Fertilizers belonging to the Oxidizing (5.1) and Miscellaneous (9) classes are regulated by a number of transport regulations, which originate from the UN model regulations, popularly known as the Orange Book (Ref 35).

The most commonly applied rules and codes are:

- International Maritime Dangerous Goods Code for Sea Transport (IMDG): Ref 37
- International Maritime Organization Code of Safe Practice for Solid Bulk Cargoes (BC Code): Ref 38
- European Agreement concerning the International Carriage of Dangerous Goods by Road (ADR): Ref 39 a, b
- International Regulation for the Carriage of Dangerous Goods by Rail (RID): Ref 40a, b, c

- Dangerous Goods Regulations (IATA Resolution 618): Ref 41
- Regulations for Transport on Inland Waterways (ADN): Ref 42 and ADNR: Ref 43

Further information about the transport regulations is given in Chapter 14.

#### 8.4 CLASSIFICATION, PACKAGING AND LABELLING DIRECTIVE (REF 33)

This applies to the product supply activity in the EU.

AN-based fertilizers and other nitrates (calcium, magnesium, potassium and sodium nitrates) have not been listed as dangerous substances in the Approved List associated with this Directive.

The labelling requirements are subject to the UN transport regulations, see Section 8.3.

#### 8.5 ENVIRONMENT RELATED CLASSIFICATION

Solid fertilizer materials are not classified as environmentally harmful or marine pollutants, as they are not particularly toxic and most are soluble in water (Ref 44). However, the addition of some micronutrients may result in classification as a marine pollutant if their threshold values are exceeded.

#### 8.6 EXPOSURE

The main potential hazard concerning exposure for the fertilizer materials considered in Section 3.2 and Chapter 5, is with respect to dust. The dust of these materials is regarded as nuisance dust. The maximum threshold for exposure to nuisance is 10 mg/m<sup>3</sup>. For reliable information reference should be made to the MSDS/SDS.

#### 8.7 HPVC AND REACH

The International Council of Chemical Associations (ICCA) put in place a voluntary programme of assembling and assessing health and environment data of many high production volume (HPV) chemicals (Ref 45). EFMA and TFI joined this programme in 2003. The health and environmental data for 25 fertilizer materials have been compiled.

All fertilizers will be subject to the EU Regulation of the European Parliament and of the Council concerning the Registration, Evaluation, Authorisation and Restriction of Chemicals (REACH) (Ref 46). The regulation is expected to come into force in 2007.

#### 8.8 PORTS AND HARBOUR REGULATIONS

At the EU level, a Directive has been put in place for enhancing ship and port facility security (Ref 47). Most countries also have their own regulations.

#### 8.9 NATIONAL REGULATIONS

National regulations in the EU member states cover trading standards as well as safety and security related aspects. Controls concerning storage differ significantly.

## 9. METHODS OF HANDLING AND STORAGE

### 9.1 GENERAL

As described in Section 7.1 certain fertilizers are classified as dangerous under the UN transport scheme as class 5.1 or 9. These fertilizers are potentially more hazardous than those not classified. Consequently, storage conditions and recommendations for the former type are more stringent than those for the latter type.

Ammonium nitrate based fertilizers can be stored, handled and transported in packaged form or in bulk. There are advantages, disadvantages and potential hazards associated with each mode. These are described below in this Chapter. Chapters 10-11 give detailed recommendations for each storage mode according to the classification of the fertilizer.

### 9.2 PACKAGES

#### 9.2.1 Requirements and Types

Packages can vary in size from the normal 50 kg bags to Intermediate Bulk Containers (IBCs) or “Big Bags” with capacities commonly up to 1 tonne. Groups of bags may be palletised for stacking by fork lift truck or other appropriate means.

The bags used for packaging fertilizers should be moisture proof and should be sealed or adequately closed so as to prevent ingress of moisture. They should comply with the relevant national/international/EU packaging regulations (so called approved bags) and should show adequate resistance to deterioration caused by the climatic conditions to which they may be exposed.

The type of bags used, their size and construction will depend on the frequency and method of handling, climatic conditions and market requirements. They should be resistant to contamination by water and oil. Polythene and polypropylene bags are widely used for this reason. Micro vents are generally provided in bags for stack stability. Precautions are needed in handling operations to avoid puncturing the bags.

The bags should be clearly labelled to indicate their contents. National and international regulations should also be complied with and where no regulations exist, the yellow “Oxidizing Agent” label and pictogram shall be on bags of class 5.1 fertilizers.

## 9.2.2 Characteristics and Safety Considerations



With packaged materials the risks of inadvertent contamination and moisture pick-up are substantially reduced and the package protects the product. Labelling of the package leads to easy identification of the product and, in some circumstances, it facilitates moving the material out of the danger area in the event of an emergency. However, particularly when the product is palletised, gaps between the bags and pallets make the penetration of heat and flame into the stack easier in the event of a fire and the collapse of the package under fire conditions can hinder fire fighting. On the other hand gaps between the stacks provide access to the stored material for initial fire fighting and create additional barriers to the propagation of detonation. Generally speaking, with a packaged material there is a higher surface area exposed to fire or heat sources.



## 9.3 BULK MATERIAL

### 9.3.1 Requirements and Types

Fertilizer can be stored in bulk form in large unconfined heaps in buildings, in heaps in bays built into storage space, in open-top enclosed bays (i.e. bunkers), bins or hoppers. (Note: There may be regional variations in the names used.) These arrangements are shown below.



*Storage building or warehouse* – Fertilizer is stored in large heaps in sheds generally at manufacturing sites. Filling is by overhead in-feed system, shovels or tippers and recovery is by shovels or scraper reclaimer. Subway conveyors underneath the heaps are not recommended for UN 2067 or UN 2071 fertilizers.



◀ *Open Bays* – Fertilizer is contained in a bay with three sides, with access from one side for recovery and/or filling. Filling is by overhead feeding system, vehicle or tippers. Recovery is by shovels or scraper reclaimer.

▶ *Open-top Enclosed Bays* – Fertilizer is contained within the bay with no access to product by vehicles. Filling is generally by overhead feeding system and a scraper reclaimer is used for recovery. Some designs have a removable front facilitating the full recovery of product and cleaning.





*Closed Bin, Hopper or Silo* – Fertilizer contained within the bin is filled pneumatically or by other suitable means and is recovered from the bottom.

The above storage systems fall into two main types.

- In storage building/warehouses and open bays the bulk material is loose on the floor and not well contained, facilitating the exposure of product to vehicles and shovels, generating fines and also ingress of spillages of other substances if not properly managed.
- In enclosed bays, closed bins, hoppers and silos, the product is well-contained, minimising exposure to foreign materials. The use of purpose built feeding and reclaim systems further reduces the contamination risk. In enclosed bays with fixed fronts emptying fully and cleaning can be difficult.

High speed thrower conveyors are not recommended for filling.

### 9.3.2 Characteristics and Safety Considerations

For bulk storage there may be (depending on the location of a fire) a lower risk of the formation of molten material compared with bagged storage, because it is difficult for the fire and heat to penetrate the heap. However, there is a greater risk of causing contamination during handling, transport and storage operations. Bulk heaps require protection from the atmosphere to prevent moisture pick-up and to avoid the formation of non-conforming materials. The heaps cannot be easily moved in the event of an emergency when, in any event, appropriate handling equipment is required. In a fire situation hollow sections in handling equipment such as improperly maintained conveyor rollers, components of shovels and hollow handrails can become a source of explosion and projectiles when contaminated by ammonium nitrate. The opportunity to find suitable bulk storage areas in users' premises is more limited. In the case of UN 2071 fertilizers in bulk, decomposition can be more readily initiated by small heat sources e.g. light bulb.



## 10. RECOMMENDATIONS AND REQUIREMENTS FOR THE STORAGE OF ALL FERTILIZERS

### 10.1 SCOPE

This chapter is applicable to all fertilizers. Additional specific requirements applicable to nitrate-based classified products are given in Chapter 11.

It is important to note that the non-classified AN-based fertilizers can contain the same components as those in the classified ones. They generally have a lower ammonium nitrate content than in the oxidizing types of UN 2067 and they will not exhibit the property of self-sustaining decomposition as do those of UN 2071.

In practice, the non-classified types are often stored in the same building with the classified fertilizers and guidance for the classified fertilizers must be followed.

In the interests of safety and quality there is an advantage in standardising good housekeeping procedures applicable to the classified and non-classified types of fertilizers. Therefore, wherever possible, follow the advice given in Chapter 11 to minimise contamination risks and fire hazards even when only a non-classified type fertilizer is stored. However, where this is impracticable, follow the minimum recommendations listed below.

### 10.2 STORES LOCATION

In selecting the location of a new fertilizer store (whether involving new construction or change of use) or in the case of development of centres of population or other activities near an existing store, consideration should be given to the risk of affecting them from the hazards of the materials stored. In the case of new stores consideration should also be given to securing the site from theft or misuse.

### 10.3 STORAGE BUILDINGS

10.3.1 The principles which determine the suitability of a building for the storage of fertilizers are based on their potential hazards. In many countries there are national regulations concerning the storage and handling of nitrate based fertilizers and due note should be taken of their requirements (e.g. capacity, size of heaps, bays etc.).

10.3.2 The buildings should be in good order and capable of shielding the products from the weather.

10.3.3 The design of the building should be such as to provide good access both to the building and within the store. The design should also facilitate safe access to emergency and fire-fighting equipment even in a fire. Seek advice from the local fire authorities as necessary. Procedures should be in place to prevent access by unauthorised persons.

10.3.4. A supply of water adequate to deal with an outbreak of fire should be available in the vicinity of the building. This should be discussed with the local fire service. In addition it is recommended that fire extinguishers are provided to deal with outbreaks of fire on equipment.

NOTE: Chemical extinguishers are not effective against fires or decomposition involving nitrate-based fertilizer.

10.3.5 All buildings should have adequate provisions for ventilation to help dissipate heat and discharge fumes in a fire or decomposition.

10.3.6 All bulk products should be stored on a single floor which should be without basement or cellar (except for channels required for product movement). Ideally, stacks of bagged material should also be stored on a single floor without basement.

Where there is more than one floor, due consideration should be given to the nature of materials stored on the various floors, their susceptibility to fire and their interaction with the fertilizers stored elsewhere in the building, e.g. due to melting and the ease of access in emergency.

10.3.7 Where combustible materials are used in construction, due consideration should be given to the potential release of toxic fumes, under fire conditions, from the products stored.

10.3.8 The restrictions described in the paragraph below do not apply to fertilizers which are nitrate-free.

Construct the buildings from not-readily combustible materials such as brick, concrete or steel, suitably protected where necessary against corrosion (see 10.3.9). Wood or other combustible materials should be avoided. However, laminated or similar fire resistant wood may be used in the construction of beams provided they do not come in direct contact with the product and a fire assessment confirms their safe use. Advice should be sought from national regulations or relevant regulatory bodies.

Floors should be of non-readily combustible material such as concrete (preferably without bitumen joints or coating) or highly filled asphalt containing typically 6-12% bitumen.

10.3.9 Galvanised items such as sheeting, vents and girders should be avoided in the construction where zinc is known to react with the stored products (e.g. with nitrate, which may be present in the fertilizer).

10.3.10 Buildings should not have internal drains, pits or channels so as to avoid trapping and confining fertilizer. However, if this is not practical, seal them securely, so that molten fertilizer cannot run into them in a fire. Also consider filling drains and channels with incombustible and fertilizer-compatible material. Particular attention should be paid to this in the case of AN-based fertilizers.

10.3.11 Provide protection against lightning where appropriate e.g. if required by national regulations or engineering codes.

10.3.12 Consider the provision of an adequate and reliable fire detection system based on a risk assessment taking account of factors such as the nature and quantities of the materials stored, the construction of the building and its location, subject to local or national requirements and advice/approval by the local fire services as appropriate. Examples of fire detection systems include smoke detection, temperature measurement, and gas (e.g.  $N_2O$ ,  $NO_x$  and  $NH_3$ ) detection. The above requirement may not be necessary based on a risk assessment in manufacturing sites where activities are continuous and therefore human presence on a regular and frequent basis is generally available.

Special consideration should be given to classified (see 3.3) materials.

- 10.3.13 Consider very carefully permanent installations for space heating and provision of electrical energy and position them in such a way that the fertilizer cannot come into contact with or be affected by them, even when the store is full. This applies to steam, hot water pipes and radiators as well as to other heat sources (whether or not insulation is provided) to runs of electric cables (which dissipate heat) and to the location of lamps. Do not use direct electrical heaters (based on a radiant exposed coil). Install the main electrical switch where it cannot come into contact with fertilizer and is easy to find, preferably outside the store.
- 10.3.14 The top of the stacks or heaps should be at least 1 metre below eaves, beams, the overhead conveyor (or its platform) and light fittings whichever is the lowest point. This is to avoid affecting the fertilizers with, for example, input of heat (from friction or other sources) and contamination. Bulkhead fittings used to protect lamps from mechanical damage offer no barrier to fertilizer which may come into their proximity. Fluorescent lamps are preferred for roof lighting because they are cooler than filament lamps. All parts of the fluorescent light assembly should be made of not-readily combustible materials. Take care to minimise dust accumulation when positioning and protecting lamps.

## 10.4 GENERAL STORAGE PRINCIPLES

10.4.1 The essentials of good store management are:

- i) Access to all storage areas, whether indoors or out, should be permitted to authorised persons only. Suitable provision should be made in the design of the store and management procedures to achieve this.
- ii) Stores should be kept securely locked when not in use.
- iii) All storage areas should have clear identification of the materials stored.
- iv) An up to date inventory of stored products should be kept, covering the type of fertilizer, quantity and location. Access to this information should be readily available in any event, as such information may be required by the emergency services, e.g. in case of a fire.
- v) Fertilizers should be moved out of the store in the order in which they were received, i.e. following the principle of “first in first out”, as far as this is practicable.
- vi) The store should be inspected regularly, e.g. at the end of the normal working day or shift, particularly when maintenance has been carried out.
- vii) Procedures should be in place to identify and handle non-conforming materials safely where appropriate (Refs 2 & 3).
- viii) Products should not be transferred to the store at abnormally high temperatures; practical limits should be set depending on the type of fertilizer in order to avoid caking and other quality problems (Ref 48), and for urea see Ref 12.

10.4.2 To minimise the risk of fire and contamination:

- i) Forbid smoking, open fires, electrical heaters with exposed radiant coils/filaments and naked flames (except when authorised for maintenance). Display NO SMOKING signs prominently, where appropriate.
- ii) Do not store fertilizers where they may be affected by any source of heat or stored combustible materials.
- iii) Do not store fertilizers where they can become contaminated with incompatible or combustible materials, such as hay, straw, oil, grease, farm chemicals (e.g. weed-killers), etc.
- iv) Ensure no stack or heap is closer than one metre to the roof support beam or light fittings.
- v) Avoid transporting flammable or combustible substances through the storage area.
- vi) Avoid activities, such as vehicle maintenance and equipment repair not directly linked to the storage area.

- 10.4.3 Good housekeeping is essential to avoid any possible hazard arising from contamination. In particular:
- i) Clean the storage area before putting fertilizers into the store and when switching from one product to another.
  - ii) Keep equipment, walls and floors (including all passageways and open spaces) clean and free from contaminants at all times.
  - iii) Take care of contaminated materials promptly and safely, as described in Chapter 12.
  - iv) Clean up and dispose of rubbish promptly and safely.
  - v) Avoid contaminating pallets, ropes, covers and other equipment with fertilizers, particularly those containing nitrates.
  - vi) Where nitrate fertilizers are involved, do not use organic substances such as sawdust as an aid to cleaning floors but use inorganic absorbents. (e.g. limestone, sand, dolomite, lavastone, gypsum and 'Sorboil' – a proprietary product)
- 10.4.4 Where excessive levels of dust are present, reference should be made to the relevant SDS for guidance on protective measures.

## 10.5 STORAGE WITH OTHER PRODUCTS

- 10.5.1 Do not store flammable or readily combustible materials such as packaging materials, pallets, gasoline, oil, sulphur, hay, straw, organic substances, and reactive chemicals such as acids, or oxidizing agents where they can contaminate or affect the fertilizer in the event of a fire. In some cases a completely empty space may be adequate with the general principle that under fire conditions the products should not affect or contaminate each other. In normal storage conditions the products should be stored so as not to contaminate each other.

Agricultural products whose reaction with fertilizers may be unknown, for example pesticides, disinfectants or weed-killers, should be treated in a similar manner.

The advice of the local fire authorities should be sought and a reference should be made to any national standards or regulations.

- 10.5.2 Do **not** store fertilizers in the vicinity of explosives.

Where explosives are stored at the same site they must be stored strictly in accordance with national explosives legislation.

- 10.5.3 Take precautions to avoid the inadvertent mixing of different fertilizer products even though they may be of the non-classified type. Such inadvertent mixing may generate non-conforming (including classified) materials with unpredictable properties. For example, mixing two non-classified AN-based NPKs may result in a classified NPK of the SSD type. For further information see EFMA guidance (Refs 2 & 3) and/or seek expert advice.

- 10.5.4 If urea is stored in the same building as AN-based fertilizers, arrange the storage so that they cannot contaminate or affect each other in the event of a fire.

## 10.6 EQUIPMENT AND VEHICLES IN STORAGE BUILDINGS

- 10.6.1 Where conveyor belts are used, consideration should be given to the provision of overload trip controls.
- 10.6.2 Keep moving parts of conveying equipment (including mobile conveyors) clean and maintained in good condition to avoid potential heat sources. Attend promptly to oil leaks particularly where they could contaminate the fertilizer.
- 10.6.3 Avoid wherever possible, hollow shafts and sections on equipment used for these fertilizers. Where they are used wash them out regularly to prevent the build up of fertilizer.
- 10.6.4 Where plastic materials are used for pipes, ducts, silos etc. it should be recognized that static electricity can be generated and appropriate care should be taken for personal safety.

- 10.6.5 Protect those parts of the equipment that contain reactive materials such as copper and/or zinc to prevent the corrosive effects of stored product on the equipment.
- 10.6.6 Electric installations must conform to national regulations including those for damp places and must be inspected regularly as to their condition of fitness. Necessary repairs should be carried out promptly.
- 10.6.7 Electric motors, transformers and other electrical equipment inside or associated with the storage building must be protected against overload and constructed in accordance with an approved national specification.
- 10.6.8 The main electrical switches, fuses, transformers and controllers should be located outside the storage area. The local switches and electrical cables within the storage area should be in a place where there is no possibility of contact with the stored product. Avoid the accumulation of dust on electrical equipment, including cables since all electrical equipment generates heat.
- Note the following points in the design and specification of the electrical equipment, for example, motors, switches etc.
- Protect electrical equipment from corrosion by keeping it separate from fertilizer as far as possible.
  - Design to give a high degree of sealing, at least to IP54 standard.
  - Minimise the use of exposed brass and copper by using, for example, nylon cable glands.
  - Minimise the use of metal parts, for example, by using polycarbonate for junction boxes, enclosures, indicator stations etc, because of the hygroscopic and corrosive nature of fertilizer materials.
  - Use fully enclosed plastic fittings for lighting, particularly in dusty areas.
  - See 10.3.11 for lightning protection
- 10.6.9 Inspect all electrical installations regularly and carry out any repairs immediately.
- 10.6.10 Vehicles, fork-lift trucks and mechanical shovels should be equipped with a fire extinguisher suitable for tackling fires on the vehicle. They should only be parked in designated safe areas and kept in a clean condition and free from oil leaks.
- 10.6.11 Maintenance requirements for equipment and vehicles are described in Chapter 13.

## 10.7 STORAGE IN PACKAGED FORM

- 10.7.1 All the requirements and recommendations of Sections 9.2 and 10.1 to 10.6 apply.
- 10.7.2 The height of stacks of bagged product should be such that they are at least 1 metre below eaves, beams and light fittings.
- 10.7.3 The maximum size of the stacks will depend on the management of the store and national legislation/guidance, if any, but they should be arranged and sized to allow ready access.
- 10.7.4 The stack should be constructed so that each stack has one passageway wide enough to provide vehicular access to facilitate dismantling in the event of an emergency.
- 10.7.5 Pallets made of wood, metal or plastic are suitable, provided they are of sufficient strength for the intended use. Empty wooden pallets and plastic bags should be stored in a suitable area separate from the fertilizer such that in the event of a fire the fertilizer will not be involved. They should not be stacked outside against the storage building. Damaged pallets should not be used. Used/returned pallets should be checked for contamination and, where appropriate, should be cleaned prior to re-use. It should be noted that in some countries there may be special requirements regarding the use or treatment of wooden pallets.
- 10.7.6 Different types of fertilizers should not be stored in the same stack. Fertilizers should not be stored with any non-fertilizer products in the same stack.
- 10.7.7 IBCs of whatever size should be stored in stable stacks. When stacking, the height of door beams and electrical fittings should be checked in relation to that of the lifting equipment.

- 10.7.8 When storing different fertilizer products and non-fertilizer materials in adjoining stacks proper consideration should be given to their possible interaction in the event of a fire.
- 10.7.9 It is important to avoid damaging the bags during handling e.g. by provision of adequate separation distances between stacks or by preventing forks of the lifting equipment contacting (and thereby damaging) the next row of bags. This can be achieved by various methods such as shorter forks, provision of buffers on forks or wider spacing between the adjacent rows of bags. Bags can also be damaged by the mishandling of pallets. Good training is, therefore, important in this respect.
- Do not use hooks to move bags, unless specifically designed for the task.
  - Do not perform operations during wet weather.
  - Do not drop bags of fertilizer from excessive heights.
  - Do not use ropes to handle bags.
  - Avoid unnecessary handling of bags.
  - Do not allow rough handling of bags.
- 10.7.10 Damaged (filled) bags in storage should be removed from the stack in order to secure stack stability and prevent further spillage.
- 10.7.11 Small quantities of spilled or contaminated fertilizer should be collected, kept separate from non-contaminated material and appropriately marked. This material can be disposed of in accordance with national regulations, EFMA guidance or other approved guidance as applicable (See Chapter 12). These materials should not be washed into water-courses or drains.

## 10.8 STORAGE IN BULK

All the requirements and recommendations of Sections 9.3 and 10.1 to 10.6 apply.

### 10.8.1 Storage Options

#### **Manufacturers' premises, large Intermediate Stores, Harbour Facility:**

Bulk fertilizers may be stored in heaps, in open or enclosed bays, in dedicated buildings or in silos.

#### **Small Intermediate Stores or Farms:**

Bulk fertilizers should be stored in silos or closed bins and other methods can be used only under the guidance of the manufacturer.

### 10.8.2 Loose Bulk in Heaps or Open or Enclosed Bays

- i) Avoid the use of wood or other readily combustible materials when storing fertilizers which can thermally decompose or can intensify a fire (e.g. those based on nitrates).
- ii) The storage space may be sub-divided into a number of bays of convenient shape and dimensions. The size of the heap should conform to national regulations.
- iii) Most fertilizers are hygroscopic and therefore when stored in bulk may absorb moisture from humid air (Ref 6). Appropriate precautions should, therefore, be taken to protect them from moisture uptake. This can be achieved by covering the heaps with water-impermeable sheeting or by the provision of air conditioning in stores. Keep the doors of the building closed as much as possible.
- iv) Take care to avoid contamination of the fertilizer in bulk heaps, e.g. by cleaning handling equipment after use and by clearing up spillage promptly.
- v) Restrict the use of cable hand lamps. All portable lamps should be protected by a glass cover and a wire cage and they should not be covered by the product. Lamps preferably should have a pushbutton contact, switching off the lamp automatically. Hand lamps with dry batteries are preferred.
- vi) The use of explosives to break up fertilizer, or adjacent heaps, that have caked in storage must be EXPRESSLY FORBIDDEN. Caked product can be broken up by mechanical means. When in doubt seek advice from the manufacturers.

- vii) The height of bulk heaps is generally restricted by a minimum distance of 1 m from eaves, beams, the overhead conveyor (or its platform) and light fittings whichever is the lowest point. This is to avoid affecting the fertilizers with, for example, input of heat (e.g. friction heat) and contamination.
- viii) Sweep up fertilizers spilled during handling operations and dispose of them in a safe manner (see Chapter 12). It is important that gangways or aisles adjacent to bulk heaps are kept clean.
- ix) Store mechanical shovels or other mobile handling equipment outside the storage building or in such a position that fertilizer in the heaps or spilled onto the floor cannot be affected by a fire involving the vehicle.
- x) Fertilizers are normally put into stores at temperatures of about 30°C to 55°C; higher temperatures should be avoided to prevent caking.
- xi) When storing different fertilizer products and non-fertilizer materials in the same building they should be well separated to prevent cross-contamination and proper consideration should be given to their compatibility including in the case of a fire.
- xii) Urea should preferably not be stored in the same building as AN-based fertilizers. If this is unavoidable, conditions should be such that neither fertilizer can affect the other in any circumstances, in particular in the case of a fire.

#### 10.8.3 Closed Bin, Hopper or Silo (See Picture in Section 9.3)

- i) Silos can be made of UV-resistant plastic (e.g. polyester), steel or similar suitable material. They should be of adequate strength to hold the stored tonnage safely. They should be installed on level well-drained ground, giving good access to trucks for loading and unloading.
- ii) The bin, hopper or silo should be capable of being thoroughly cleaned before the fertilizer is introduced and so constructed that moisture absorption and product contamination are avoided during storage.
- iii) For normal security reasons, the silos should be fenced against unauthorised access, but allowing access to the spreading device, which can be filled under the silo.
- vi) Silos should preferably be installed outdoors, at a safe distance from any combustible material e.g. fuel tanks.
- v) A supply of water adequate to deal with an outbreak of fire should be available in the vicinity of the silo where there is a risk of fire. In addition it is recommended that fire extinguishers are provided to deal with outbreaks of fire on any equipment.

NOTE: Chemical extinguishers are not effective against a fire or decomposition involving nitrate based fertilizers.

- vi) Silos must be provided with a venting device, to prevent vacuum collapse during unloading (tapping), to enable the discharge of pneumatic air during filling operations and to enable the discharge of gases generated in the event of a fire. Normally one of the filling or de-aeration pipes can be used for this purpose, however, the venting requirement in the event of a fire should be assessed.
- vii) Only one fertilizer product should be stored in each silo at a given time. The silo may be used for other products only after thorough cleaning. (See Section 10.8.3 (ii)).
- viii) When using pneumatic air for conveying purposes take care to prevent contamination (e.g. oil and dust).
- ix) When using plastic pipes, take care against the build up of static electricity during loading and unloading.

## 10.9 OUTSIDE STORAGE OF BULK AND PACKAGED FERTILIZER

10.9.1 The storage is regarded as outside when the storage area is not protected by walls and a roof. Outside storage is generally suitable for packaged products. Bulk fertilizers should only be stored outside in closed bins, hoppers or silos (See Section 10.8.3)

The requirements and recommendations of Sections 10.1 to 10.2 and 10.4-10.7 apply as appropriate.



10.9.2 Many of the general principles for the storage of non-classified fertilizers apply just as much to those stored in the open as to those stored in a building. The recommendations made concerning co-storage with other products for inside storage (see Section 10.4.1) equally apply for outside storage. Special care should be taken to avoid the storage in close proximity to combustible materials such as wooden pallets, gasoline etc. even when separated by a boundary fence. Vehicles should be parked in a designated area at a safe distance from the stored products when not in use.

The design should ensure that good and safe access to the storage area and to the product stored within is available to emergency and fire-fighting equipment even in the event of a fire/decomposition. Exchange information with the local fire authorities where appropriate.

Consideration should also be given to the provision of adequate lighting.

10.9.3 Storage areas should:

- Be on level well-drained ground without projections or snags which could puncture or tear the packages.
- Be surveyed frequently when located near to population centres particularly where there is a risk of vandalism.
- Be protected against unauthorised access e.g. by means of a fence. Warnings against unauthorised entry should be posted.

10.9.4 Repeated temperature cycles may cause physical deterioration of some products (See Section 5.1). This physical deterioration may result in the breakdown of the fertilizer particles and damage to packages. The product should be protected from direct sunlight e.g. by white plastic sheeting. This can best be achieved by resting the sheet on a single layer of pallets above the stack. The layer of pallets provides a thermal insulating effect.

10.9.5 It is good practice:

To store the first layer of packages (50 kg bags or IBCs) on pallets to prevent damage from ground projections and to minimise water ingress from surface water.



To protect the stacks with plastic sheeting against rain and dirt/dust. The sheeting, preferable white to reduce heat absorption, should be adequately secured against adverse weather conditions by, for example, ropes and/or weights. Care should be taken to avoid water accumulation on the sheets on top of the stack.

#### 10.9.6 Stack sizes

The maximum height of the stack should take into account stack stability, bag strength and safe handling when loading, unloading and sheeting. The maximum stack size should be in conformity with the national legislation, if any.

## 11. ADDITIONAL RECOMMENDATIONS AND REQUIREMENTS FOR THE STORAGE OF CLASSIFIED FERTILIZERS (UN 2067 AND 2071)

### 11.1 SCOPE

This section gives additional recommendations to those described in Chapter 10, for the storage of fertilizers which are classified, as described in Chapter 7. Taking into account the hazardous properties described in Chapter 6.

### 11.2 STORES LOCATION

Stores and public buildings such as a hospital, school or institution, which cannot readily be evacuated when exposed to any hazard associated with the storage, should not be built in close proximity to each other. Advice should be sought from the relevant authority as to the location of the store. In addition, the requirements of the Seveso Directives and any associated legislation should be taken into account.

### 11.3 STORAGE BUILDINGS

11.3.1 Construct the buildings from not-readily combustible materials such as brick, concrete or steel, suitably protected where necessary against corrosion (see Section 10.3.9). Plain/common wood or other combustible materials should not be used. Laminated or similar fire resistant wood, may be used in the construction of beams provided they do not come into direct contact with the product and a fire assessment confirms their safe use. Advice should be sought from national regulations or the relevant regulatory bodies.

Floors should be of non-readily combustible material such as (a) concrete, preferably without bitumen joints or surface coating or (b) highly filled asphalt (typical grade 6-12% bitumen).

### 11.4 GENERAL STORAGE PRINCIPLES

11.4.1 These fertilizers should not be put into the store at a temperature above 55°C as a good practice, to preserve product quality and to avoid the need to break up severely caked material by mechanical means. One of the most effective ways to prevent caking is by reducing the product temperature as far as practically (and economically) possible; all other actions such as more intensive drying, use of

additives and changes in recipe /composition, are less effective. A temperature below the 55°C limit may be set for more quality sensitive products. Where there is a need to exceed this temperature a risk assessment should be carried out.

## 11.5 STORAGE WITH OTHER PRODUCTS

11.5.1 Extreme care should be taken with the storage of non-fertilizer products, in particular combustible and reactive chemicals, in the same storage area as classified ammonium nitrate based fertilizers. Non-fertilizer products should be separated by means of a fire-fighting barrier, the resistance of which has been assessed according to the expected amount and nature of the other products to be stored.

11.5.2 Types of materials which are considered to be potentially hazardous are:

1. Combustible materials giving rise to a fire hazard and thermal radiation.
2. Materials which are chemically unstable in themselves or which can give reactive mixtures when in contact with ammonium nitrate.
3. Materials and articles capable of giving rise to a release of energy in an explosive way.
4. Materials capable of releasing toxic fumes when involved in a fire or in a reaction with ammonium nitrate.

As a basic principle these types of materials should not be stored in the same storage building. In exceptional circumstances it may be permissible to store small quantities in the same building, if, based on a safety assessment, it can be shown that any risk of the stored classified fertilizers being affected, including under fire conditions, by any of the above materials, is acceptably low.

Examples of the above types of materials are:

- i) Solid or liquid materials sensitive to explosive decomposition (e.g. organic peroxides).
- ii) Flammable liquids such as gasoline, lubricating fluid, coating oil and fuel oils.
- iii) Gas cylinders including those for welding operations.
- iv) Oil-based pesticides.
- v) Corrosive liquids, acids and other reactive substances such as chlorates, hypochlorites, chlorinated organic compounds, bleaching powder, chromates, nitrites, copper and zinc salts, permanganates.
- vi) Readily combustible solid or liquid products such as sulphur, powdered metals and organic substances such as hay, straw, grain and animal feedstuffs.
- vii) Products such as quick-lime and calcium cyanamide which generate heat in the presence of moisture.
- viii) Products such as cement, lime, basic slag and other alkaline substances which will liberate ammonia gas from the ammonium nitrate based fertilizers.
- ix) Other agricultural products whose behaviour towards ammonium nitrate may be uncertain, for example branded pesticides, disinfectants or weed killers.

11.5.3 Materials, which are thermally stable and known to be non-reactive with AN (e.g. DAP, sodium nitrate, limestone and calcium ammonium nitrate), may be stored in the same storage area as the fertilizer, but the contamination of products in bulk should be avoided.

11.5.4 Fertilizers belonging to class 5.1, UN 2067 (oxidizers) shall not be stored in the same stack, heap or bay as those belonging to class 9, UN 2071 (SSD type) which could act as a heat source in case of a decomposition.

11.5.5 If urea is stored in the same building as AN based fertilizers, arrange the storage so that they cannot contaminate or affect each other even in the event of a fire (see 6.3).

## 11.6 EQUIPMENT AND VEHICLES IN STORAGE BUILDINGS

- 11.6.1 Conveyor belts and other equipment used for handling ammonium nitrate based fertilizers, particularly in a fixed installation, should not have any parts fabricated from readily combustible material. In this respect due regard should be paid to conveyor belts (e.g. type of rubber and flame retardant properties) and associated protective systems such as overload trips, anti-static provisions, high temperature alarm/trips and drum rotation failure trips.
- 11.6.2 **Hollow shafts and sections should be avoided on equipment in service with fertilizers wherever possible.**
- 11.6.3 Vehicles, fork-lift trucks and mechanical shovels should not be allowed access to any store unless free from oil and fuel leaks and should be carefully maintained to that end. They should be carefully cleaned after use, preferably in a dedicated area, to prevent any product coming into contact with fuel, oil or grease.
- 11.6.4 When not in use for loading or unloading, fork-lift trucks should preferably be parked outside the store or in an approved part of the store building which is segregated from the fertilizer by a fire barrier. Mechanical shovels used for bulk materials should be dedicated to single stores and not removed other than for major repairs. When parked they should be segregated as above.
- 11.6.5 Do not park vehicles in any storage building/area other than for the purpose of loading or unloading and do not leave their engines running.
- 11.6.6 Take care to prevent exhaust gases from internal combustion engines from heating stored fertilizer. Consider the installation of spark arrestors.
- 11.6.7 Preferably use diesel or electrically powered vehicles and not petrol/gasoline powered vehicles in stores. Do not refuel vehicles within the storage building/area. The recharging of batteries should be carried out in a separate approved area.
- 11.6.8 It is recommended that there should be a traffic plan for the movements of vehicles for off-loading and loading fertilizers and other related materials.

## 11.7 STORAGE IN PACKAGED FORM

All the requirements of Sections 9.2, 10.1 to 10.7 and 11.1 to 11.6 apply.

The maximum permitted stack sizes are subject to regulations or codes in many countries.

## 11.8 STORAGE IN BULK

All the requirements and recommendations of Sections 9.3, 10.1 to 10.6, 10.8 and 11.1 to 11.6 apply.

### 11.8.1 Storage Options

Various methods of storage in bulk are described in Section 9.3.

#### **Manufacturers' premises, large intermediate stores, harbour facility:**

Storage in bulk in storage buildings/warehouses, open or enclosed bays or separate silos is acceptable.

#### **Small intermediate store or farm:**

Storage in silos or closed bins (9.3.1) is the preferred and recommended procedure. Other methods can be used under the strict guidance of the manufacturer and in conformance with national legislation.

### 11.8.2 Loose Bulk in Heaps or Open or Enclosed Bays

- i) Fertilizers spilled during handling operations should be swept up at once and disposed of in a safe manner (see Chapter 12). Care should be taken to avoid the build up of compacted fertilizer on the floor.
- ii) These fertilizers should not be put into the store at temperatures in excess of 55°C. A risk assessment should be carried out where there is a need to exceed this temperature.

- iii) It is preferable not to store oxidizer (UN 2067) and SSD-capable (UN 2071) fertilizers together in the same building. However, where they are stored in the same building there should be strict procedures to ensure that there is effective separation between them so that they cannot affect each other in a fire or decomposition. Other fertilizers may be stored in adjacent bays, following the guidance given in Section 11.5.
- iv) The building should not be used at any time for the storage of any non-fertilizer material, including packaging materials and pallets unless these are separated from the fertilizer by a suitable fire break. A fire in these packaging materials should not be able to affect the fertilizer.

#### 11.8.3 Closed Bin, Hopper or Silo

Classified ammonium nitrate based fertilizers may be stored in bins, hoppers or silos, provided these are only used to hold fertilizer.

### 11.9 OUTSIDE STORAGE OF BULK AND PACKAGED FERTILIZERS

As 10.9.

## 12. MANAGEMENT OF NON-CONFORMING AND ANCILLARY MATERIALS

### 12.1 GUIDANCE FOR OFF-SPEC AND REJECT MATERIALS

Descriptions, definitions and management of non-conforming, off-spec and reject materials are given in EFMA guidance documents, Ref 2 (for producers) and Ref 3 (for distributors).

Non-conforming materials include, for example:

- off-spec products from processes
- off-spec products returned from customers
- products deteriorated in storage
- spillages: clean or contaminated
- various accumulations in and around equipment (e.g. deposits of mixtures of product and coating agents in coating drums, contaminated accumulations underneath conveyor belts).

Various methods are possible for the safe utilisation of the non-conforming materials, depending on the extent and nature of the deviation or degradation. These methods are reviewed in detail for various types of AN-based products, urea-based products and a range of raw materials. Of the various possible options listed, those suitable for a specific non-conforming material depend on a number of factors: e.g. the availability of suitable manufacturing processes on the site with a potential for recycle; the availability of other manufacturing processes, which can use them as process materials; and marketing as saleable products. It should be noted that not all options listed might apply to any particular reject material under consideration.

Importers, distributors and merchants should also evaluate their particular situation and select the most suitable solution after carrying out a risk assessment.

## 12.2 ANCILLARY MATERIALS: PALLETS, PACKAGES AND OTHER MATERIALS

These include, for example, contaminated or broken pallets, ropes or covers, damaged or discarded fertilizer bags and other packaging materials. Used packages and other materials should be recycled, if possible, or disposed of safely by other means in conformity with national regulations. See also 10.7.5.

## 13. MAINTENANCE OF EQUIPMENT AND VEHICLES

- 13.1 Equipment, particularly its moving parts, should be regularly cleaned and kept in good condition. Care should be taken to avoid oil leaks, particularly where this could contaminate the fertilizer.
- 13.2 Refuelling of vehicles and as far as possible, the greasing and oiling of vehicles and mobile equipment should be done outside the building. No oil or grease should be kept in those parts of the building where it could become mixed with ammonium nitrate based fertilizers or accumulated fertilizer dust and residues.
- 13.3 Maintenance work in the storage area should be carried out only with specific authorisation (e.g. hot work permit or equivalent). Any operation which requires the use of heat such as welding or flame-cutting, should be performed under supervision. Precautions should be taken to prevent the initiation of fire, for example, by hot particles or sparks from welding. At the completion of the operation the work area should be checked to ensure that it has not been adversely affected.
- 13.4 Maintenance or repairs on equipment handling fertilizer should exclude, as far as possible, operations using heat, such as welding and brazing, unless under strict control. These operations should only be carried out after proper cleaning and inspection of hoppers or equipment (in particular, hollow sections) and a strict procedure must be in place to ensure proper cleaning. These devices may contain, or may be coated with, fertilizer residues which can be easily overlooked. On heating, the fertilizer residues produce gaseous products some of which are toxic. Fertilizers trapped in confined spaces and heated can undergo a decomposition leading to pressure build-up and possibly an explosion. This is particularly the case with respect to nitrate and urea fertilizers.
- 13.5 If, due to unavoidable reasons, welding has to be carried out and it is in such a position that hot waste from weld (dross) or heated metal could fall amongst the products, the latter must be covered (for example with damp sacking) prior to commencing the work. The area should be kept under observation for several hours after the work is completed. Particular care must be taken when performing such hot work over or in the vicinity of moving parts such as belts which could convey hot metal parts into a fertilizer storage area. All such hot work should be covered by a permit system.
- 13.6 Electrical repairs should be carried out immediately where there is a danger of sparking or heat affecting fertilizer.



- 13.7 Any insulation removed to carry out work should be replaced promptly on its completion.
- 13.8 A record should be kept of inspection and repairs.

## 14. TRANSPORT

### 14.1 INTRODUCTION

The essential principles for storage apply equally to transport; namely avoidance of contamination, prevention of a fire, care during repair and maintenance of transport units, provision of appropriate hazard information and product security.

As described in Section 8.3, transport regulations (e.g. ADR, RID, IMDG, ADN and/or corresponding national regulations) apply to classified products such as oxidizers of class 5.1. These regulations specify various requirements such as packaging and labelling. Companies involved in the transport of fertilizer materials classified as dangerous goods must appoint a Dangerous Goods Safety Advisor (DGSA) (Ref 49).

There are no specific requirements in road and rail transport regulations for compound fertilizers belonging to UN 2071. For air transport, fertilizer falling within the composition specified in UN 2071 remains classified as UN 2071 irrespective of the result of the trough test.

Requirements relating to the security of dangerous goods in transport are incorporated in these regulations. They specify a number of general provisions relating to the security of all classified dangerous goods when transported. Some selected dangerous goods are listed as High Consequence Dangerous Goods. These require additional safeguards such as the provision of security plans. AN and AN-based fertilizers of Class 5.1 (oxidizers) when transported in bulk (i.e. unpackaged form) come within the scope of the rules for High Consequence Dangerous Goods. The European Chemical Industry Council (CEFIC) has issued an industry guidance relating to security provisions for transport by road specified in ADR (Ref 50).

A European regulation is also in place to enhance security in ship and port facilities. Its main objective is to introduce and implement Community measures aimed at enhancing the security of ships used in international trade and domestic shipping and associated port facilities in the face of threats of intentional unlawful acts (Ref 47).

## 14.2 GENERAL PROVISIONS FOR ALL TRANSPORT MODES

Care should be taken to prevent spillages. This is valid for all loading/unloading areas with particular attention to be paid to multipurpose equipment such as weighbridges and transportable cranes.

Contamination is to be avoided, especially by non-compatible materials.

Fire extinguishers are provided on transport units (e.g. vehicle cabs and ship bridges) primarily for fighting local fires; they are not intended for the fertilizer load. However, if fertilizers are involved in a fire and are decomposing, only water must be applied.

Smoking must not be permitted in all loading and unloading areas when handling classified products. It is good practice to apply this principle to all fertilizer materials.

Do not load damaged bags. Unload any that are discovered and clean up any spillage.

Ensure that the decks of transport units are dry, clean, free from incompatible materials and free from snags which could cause damage to bags before the loading of the product.

Additional recommendations for each mode of transport are given below.



## 14.3 ROAD TRANSPORT

14.3.1 The provisions of 14.1 and 14.2 apply

14.3.2 Take care when loading/unloading vehicles to avoid any part of the load or spillage from the load coming into contact with the exhaust pipes. Care should also be taken to prevent the load being thermally affected by the exhaust pipes and catalytic converters.

14.3.3 Hauliers should instruct their drivers to keep loads within their control throughout the journey and to take care when the vehicle is parked, bearing in mind the security aspects.

14.3.4 Do not allow vehicles to enter stores unless free from oil or fuel leaks.

14.3.5 For classified materials the provisions of ADR apply.

Special attention should be given to:

- Marking and labelling
- Provision of TREMCARDS

- Training
  - Security provisions.
- 14.3.6 Vehicles should not be parked in the storage areas unless being loaded or unloaded. Vehicles should not be left with the engine running unless under supervision.
- 14.3.8 For packaged product the following apply:
- Distribute loads evenly over the deck of the vehicle as far as is reasonably practicable in order to maintain stability.
  - Vehicles carrying fertilizer should not carry incompatible materials as part loads. AN-based fertilizers should not be carried together with combustible materials, acids or other incompatible materials particularly in the case of classified fertilizers.
  - Sheet and securely fasten bagged material in a safe manner after loading. A safe system for the sheeting of the load on flat-bed lorries or taut liners should be provided.
- 14.3.9 For bulk products the following apply:
- Ensure that the vehicle is clean and dry and is inspected prior to loading. This is important both from safety and quality points of view.
  - Any vehicle used to transport fertilizer alternately with other products, e.g. animal feeding stuffs, should be adequately cleaned between each operation to avoid cross contamination.
  - The load-carrying compartment should be constructed of impervious, not-readily combustible materials.
  - An undamaged sheet should be used to cover the whole of the cargo carrying compartment adequately. The sheet should be of a suitable material (e.g. coated synthetic fibre.)
- 14.3.10 Where vehicles incorporate a load heating facility it should be switched off when fertilizers are being transported.



## 14.4 RAIL TRANSPORT

- 14.4.1 Apply the national rail transport regulations noting that these may differ from country to country.
- 14.4.2 The transport must be carried out in accordance with the RID regulations when transporting any classified material.
- 14.4.3 Distribute bags evenly in the wagon and in such a way that any movement of the load does not prevent the opening of the doors.
- 14.4.4 Care is needed with bulk loads to ensure the closure is effective to prevent moisture ingress and product leakage.

## 14.5 SEA TRANSPORT

- 14.5.1 Sea transport deserves a high degree of attention and careful management as this involves relatively large quantities of materials, long travel distances and often international shipments. A number of requirements have been specified for the safe transportation for classified materials in regulations, e.g.
  - IMDG Code for the transport of packaged goods by sea
  - IMO BC Code for the transport of bulk material by sea

These regulations specify certain safety related requirements for the products, e.g. resistance to detonation, which must be complied with.

EFMA has published a guidance document for the sea transport of AN-based fertilizers (Ref 51) and, therefore, only an overview is given below.

- 14.5.2 Restrictions concerning the stowage of other goods must be adhered to as specified in the sea transport regulations.
- 14.5.3 The holds of ships should be checked to ensure:
  - Cleanliness (including on top of the beams)
  - no moisture
  - no impurities
  - no electrical cables or lamps in contact with the cargo
  - no **soft wood** in contact with the cargo
  - no hot pipes and other potential sources of heat in contact with the cargo
  - all hatches can be tightly closed prior to loading and are so closed after loading.
- 14.5.4 Vessels should be of sound construction with holds constructed of impervious not-readily combustible materials. Ensure that various detailed requirements described in the relevant regulations/codes for the vessels are met. If there are wooden beams or bulk heads, treat these to render them not-readily combustible when transporting AN based fertilizers. Only a minimum of dry dunnage should be used.
- 14.5.5 Hatches should be designed, constructed and maintained so as to prevent the ingress of water. They should be fully closed once loaded to keep the cargo dry.
- 14.5.6 The design of electrical installations and fittings in holds should be such as to minimise the risk of mechanical or chemical damage. They should be maintained to a high standard. Special precautions for AN-based fertilizers are given in the EFMA guidance (Ref 51).
- 14.5.7 When the vessel is in the harbour, hot work can only be performed with the permission of the representative from the harbour terminal and must follow the same authorisation procedures as those required for work in the local harbour area.
- 14.5.8 Stow ammonium nitrate based fertilizer clear of potential sources of heat.
- 14.5.9 Keep the use of wooden pallets and wooden dunnage to a minimum, when shipping packaged product.

14.5.10 For bulk product the following apply:

- Inspect all fertilizer before and during loading and, if contaminated, halt the loading operation.
- If fertilizer is found to be contaminated on unloading, the contaminated portion should be stored separately. Identify the contaminant and take appropriate action based on expert advice.
- Do not load or unload when it is raining, snowing or hailing and make every reasonable effort to ensure that product does not become damp. Batten down hatches immediately after loading has been completed and cover with tarpaulins where appropriate.
- Consider the angle of repose, as material with a low value can shift during rough seas (Ref 38).

## 14.6 INLAND WATERWAYS

14.6.1 In Europe this is covered by ADN and ADNR regulations (Refs 42, 43).

The requirements of 14.1, 14.2 and the appropriate parts of 14.5 apply.

14.6.2 Vessels carrying substances of class 5.1 in bulk shall not carry any other goods.

14.6.3 Restrictions concerning the stowage of other goods must be adhered to as specified in the sea transport regulations.

14.6.4 For bulk cargo, all parts of the holds and hatches, which can come into contact with the product, must be made out of metal or wood with a density of at least 0,75 kg/dm<sup>3</sup> (air-dry).

14.6.5 During the transport of bulk product combustible materials must not be allowed to enter the same holds.

14.6.6 For bulk product the following should be applied:

- Cover the whole cargo adequately after loading, with an undamaged sheet, where appropriate, (e.g. for long journeys) and batten down hatches immediately after loading has been completed.
- In certain countries, the transport via inland waterway in bulk is only allowed with the specific permission of the national authorities. There may also be additional national requirements concerning ship, equipment, lot size, etc.
- Stow the bulk cargo evenly for the ship's sailing safety.

14.6.7 These regulations specify the safety related requirements for the products such as those in the BC Code, which must be complied with.

## 14.7 AIR TRANSPORT

Air transport of fertilizers is very uncommon except for the occasional need concerning small samples. Reference should be made to the IATA code.

Passengers should avoid carrying samples of fertilizers with them on flights.

## 15. SAFETY FACILITIES AND TRAINING

### 15.1 SAFETY AND FIRE FIGHTING EQUIPMENT

All stores, outdoors or indoors, should have a reliable means of alerting the emergency services e.g. by a telephone system.

Stores should be adequately equipped with fire-fighting equipment which should include:

- A fire water supply via a typical water hydrant from a piped supply or a reservoir. Factors such as accessibility and protection against adverse weather conditions, e.g. frost and snow, should be considered. The local fire service should be made aware of the water supply facilities and should approve static water tanks or fire hydrants.
- A standard water supply capable of reaching all parts of the storage area, or an adequate supply of water extinguishers for fighting initial outbreaks of fire.
- Chemical extinguishers for fires on equipment where fertilizers are not directly involved.

Specialist personal protective equipment such as self-contained breathing apparatus should be provided in accordance with local/national requirements and in large stores, e.g. Manufacturers' premises, where adequate technical back up facilities are available. These shall be of an approved type properly maintained and regularly inspected. (Where such equipment is not provided, see Chapter 18 for safe escape from toxic fumes).

Records of all maintenance and inspection of all safety equipment shall be kept.

See Section 10.3.12 concerning the provision of a fire detection system.

### 15.2 TRAINING

All site personnel and visitors should be made aware of the emergency procedures and safety information.

Personnel involved in the handling and storage of fertilizers should be adequately instructed as to the potential hazards of the raw materials and fertilizers stored and the precautions to take. Information given in Chapter 6 can be used for this purpose.

In addition to the above, train personnel (including contractors) in:

- correct storage and handling procedures for all materials, including non-conforming products (particularly AN-based, see Chapter 12).
- correct use of safety equipment.
- emergency procedures (see Chapter 18).
- fire-fighting procedures.
- procedures relating to work permits.

Keep records of all training.



## 16. SECURITY

Avoid storing fertilizer adjacent to public highways or where securing the site from theft or misuse could be difficult.

A system should be in place to authorise and control personnel who can enter the site or store. In a relatively large organisation this can be achieved by a badge or access card system.

Controlling the entry of unauthorised persons to storage premises, particularly where nitrate-based fertilizers are stored is strongly recommended and note should be taken of national/local requirements in this regard. Effective and secure fencing should be provided, where appropriate. In some situations, such as large outdoor storage in vulnerable areas, it may be advisable to provide camera-linked TV monitoring or infra-red alarm systems. Advice in this regard may be sought from the appropriate bodies, such as security services.

In the event of a fire it is important that the facilities are such that speedy control is possible. In this respect, good access both to and within the store is important.

For security requirements relating to transport, see Section 14.1.

## 17. CONSEQUENCE ANALYSIS AND ENVIRONMENTAL CONSIDERATIONS

### 17.1 INTRODUCTION

The three main potential hazards to consider for fertilizer solid raw materials and products in terms of damage to people, property and environment are

- release of toxic fumes either due to fire and/or decomposition
- explosion
- spillage on land or in water.

### 17.2 TOXIC FUME HAZARD

Most fertilizer materials thermally break down, when heated, releasing gases some of which may be toxic or harmful. Fertilizers based on ammonia tend to be more prone than others in this regard and they include, for example, ammonium nitrate and AN-based fertilizers, MAP, DAP and urea. They give off ammonia gas when decomposing. Those containing AN also release oxides of nitrogen. NPK fertilizers can give off a number of gases (e.g. ammonia, oxides of nitrogen and hydrogen chloride) depending on the source materials used.

The nitrates of potassium, sodium and calcium are relatively more stable but when strongly heated can give off oxides of nitrogen.

For the preparation of Safety Reports and emergency plans under Seveso regulations it may become necessary to do consequence analysis for certain accident scenarios such as a major fire with the evolution of toxic fumes. Such consequence analysis will involve the prediction of the concentration of toxic gases at various distances as the fumes disperse downwind in the atmosphere. Dispersion models are available from a number of organisations. Such models will require the 'source' term as an input, which is the rates of release of the toxic components. For straight AN the relevant information is available from a number of fire tests carried out by the UK's Health & Safety Executive (Ref 52). Information about indicative compositions of the fumes released from AN-based NPK fertilizers is given in Section 6.1.9 and Ref 24.

## 17.3 EXPLOSION

Most fertilizers are free from explosion hazards. Those fertilizers which can present explosion hazards (see Chapter 6) are required to pass the EC detonation test to prove they have high resistance to detonation and, therefore, the risk of a major explosion involving detonation of a significant amount of the stored fertilizer is extremely small. However, if for any reason a consequence analysis of a scenario involving a detonation in a stack or heap is required, the main point of consideration would be overpressures generated by the blast wave. Such overpressures can be derived from an estimation of the TNT equivalent and the efficiency of explosion. Guidance on these aspects is available from papers published by TNO (Refs 53 and 54).

## 17.4 ENVIRONMENTAL HAZARDS

### **Ammonium Nitrate**

Ammonium nitrate has low aquatic toxicity and does not present a major hazard to the environment if spilled on land. It is widely used as a fertilizer as it supplies nitrogen for plants. It is readily soluble in water and biodegradable; therefore, it is not persistent and does not bioaccumulate.

The potential harm to the aquatic environment can be from:

- toxicity of free (non-ionised) ammonia
- oxygen depletion due to nitrification of ammonia/AN
- eutrophication due to nitrate

AN can create toxic effects when dissolved in water through the production of free (or non-ionised) ammonia. The extent of this reaction is very low below a pH of 7 and thus for most fertilizer products the toxic risk to the aquatic environment is negligible in practice.

Nitrification of ammonia/ammonium ion to nitrate by bacterial action is a relatively slow process and therefore discharge into a running stream or tidal estuary waters is unlikely to result in harm.

However, a high ammonium nitrate concentration in confined surface waters may induce the proliferation of algae (eutrophication) or, eventually, contamination of ground water by nitrates.

### **Urea**

Urea has low aquatic toxicity and does not present a major hazard to the environment if spilled on land. Being a nutrient for plants it is widely used as a fertilizer. It is readily soluble in water and biodegradable; therefore, it is not persistent and does not bioaccumulate.

### **Potassium nitrate**

Potassium nitrate will easily go into solution in the soil and dissociate completely into its ions. Both ions can participate in absorption and ion exchange processes. Under aerobic conditions the nitrate ion is chemically and biologically degradable. Like ammonium nitrate a high potassium nitrate concentration in confined surface waters may induce the proliferation of algae (eutrophication) or eventually, contamination of ground water by nitrates.

### **Sodium nitrate**

Sodium nitrate will easily go into solution in the soil and dissociate completely into its ions. Both ions can participate in absorption and ion exchange processes. Under aerobic conditions the nitrate ion is chemically and biologically degradable. Like ammonium nitrate a high sodium nitrate concentration in confined surface waters may induce the proliferation of algae (eutrophication) or, eventually, contamination of ground water by nitrates.

**Calcium nitrate fertilizer (CAS No. 15245-12-2)**

Calcium as an ion can participate in absorption and ion exchange processes. Under aerobic conditions the nitrate ion is chemically and biologically degradable. As with other nitrates, a high concentration in confined surface waters may induce the proliferation of algae (eutrophication) or, eventually, contamination of ground water by nitrates.

**Monoammonium phosphate (MAP)**

Monoammonium phosphate may be harmful to aquatic life at relatively high concentrations; however, it has low acute toxicity to fish. Large-scale release may lead to the eutrophication of waterways.

MAP easily dissolves forming the ions  $\text{NH}_4^+$  and  $\text{H}_2\text{PO}_4^-$ . The ammonium is converted to nitrate whilst the latter is converted to  $\text{PO}_4^{3-}$  and both are easily taken up by plants.

**Diammonium phosphate (DAP)**

Diammonium phosphate may be harmful to aquatic life at relatively high concentrations. However, it has low acute toxicity to fish. Large-scale release may lead to eutrophication of waterways.

DAP easily dissolves forming the ions  $\text{NH}_4^+$  and  $\text{HPO}_4^{2-}$ . The ammonium is converted to nitrate whilst the latter is converted to  $\text{PO}_4^{3-}$ ; and both are easily taken up by plants.

**Superphosphates**

Superphosphates readily dissolve forming mono calcium phosphate. In calcareous, neutral or slightly acidic soil, it is quickly precipitated as available dicalcium phosphate, by calcium ions present in the soil solution. In acidic soil, phosphate is precipitated by iron and aluminium compounds.

## 18. EMERGENCY PROCEDURES

### 18.1 INTRODUCTION

All personnel should be made aware of the nature of the materials stored.

For every storage location there should be a written procedure to be followed in the event of an emergency e.g. a fire and/or release of toxic fumes. All personnel should be instructed and have regular practice in these emergency procedures.

### 18.2 EMERGENCY ACTION IN THE EVENT OF FIRE OR FERTILIZER DECOMPOSITION

If smoke or fumes are observed in a fertilizer store and if it is safe to do so (i.e. not being affected by the flames, fumes or smoke), check to see if flames can be detected. If flames are seen, then a fire involving combustible material or the building itself is likely. If no flame can be seen, then fertilizer decomposition is probably taking place.

- Raise the alarm and evacuate the storage area.
- Call the Fire Services and advise them that fertilizers are involved.

**In the case of a fire with visible flames:** Provided it does not compromise your safety and route of escape, locate the source of the fire and extinguish it by the most appropriate method available. This may apply to situations where ancillary material may be involved (e.g. rags, pallets, rubbish and oil/lubrication in a mechanical shovel), which is not in direct contact with the fertilizer.

**In the case of fertilizer involvement or decomposition (with or without combustible material burning and affecting the fertilizer):** e.g. this may apply to situations where pallets in stacks may be on fire or fertilizer may be undergoing thermal decomposition. Urea, DAP and AS when involved in a fire could release ammonia fumes. AN-based fertilizers can give off, in addition, NO<sub>x</sub>, N<sub>2</sub>O and in the case of NPK formulations other gases (see Chapter 6). Some fertilizers e.g. MOP, TSP and SSP are very unlikely to decompose under normal fire conditions.

- Avoid breathing the fumes; they can be toxic.
- Keep all personnel not involved in fire fighting away from the scene of the fire and in particular, keep people away from the fumes.
- Check what types of fertilizers are stored.
- **Provided it does not compromise your safety and route of escape**, ensure maximum ventilation as quickly as practicable by opening all doors, windows and roof vents (provided it does not accelerate the burning of combustible materials); **otherwise**, leave this to the emergency services. As far as possible, this should be done from outside the building.
- If ammonium nitrate based fertilizers are involved, do not use chemical extinguishers, foam or sand; attempts to smother a fire are useless and potentially hazardous. In particular, never try to smother the fire with steam.

**Note:** outbreaks of fire on equipment where the fertilizer itself is not directly involved may be extinguished by these means.

- Advise the Fire Services on their arrival of the types of fertilizers that are involved (particularly point out if AN-based fertilizers are present) and that self-contained breathing apparatus may be required. Safety Data Sheets of the products involved should be given to them.
- Protect drains by suitable materials such as bags of sand to prevent the ingress of molten ammonium nitrate and avoid any decomposition of AN taking place in confinement.
- Fight the fire from upwind and from outside the buildings, if possible. Use self-contained breathing apparatus if entering fumes.
- Where combustible material is the source of the fire extinguish this source as a matter of priority.
- Tackle a major decomposition of fertilizer with the effective application of water, preferably with high pressure water jets directed at the seat of the decomposition. This is particularly important in the case of fertilizers of the SSD type, UN 2071, for which special lances such as Victor lances are recommended. See Appendix 3.
- In a minor decomposition try to remove the decomposing material from the main heap and direct copious quantities of water on the seat of the decomposition.
- If necessary, keep adjacent fertilizer cool by spraying with water. In this respect particular care is needed in the case of fertilizers capable of SSD, i.e. those belonging to UN 2071 (See Chapter 6).
- Under severe fire conditions the application of water to hot ammonium nitrate may cause eruptions of steam and splashing of the melt. Fire-fighting personnel should take all necessary precautions whilst continuing to apply water to the seat of the fire.
- After the fire, clean up the area efficiently under the supervision of a competent person. Dispose of damaged or contaminated fertilizer in a safe manner as described in Chapter 12.
- Where necessary advise the relevant local and/or water authority if water contaminated with ammonium nitrate has entered watercourses etc.
- Continue supervision until there is no further risk of decomposition or recurrence of the fire.

### 18.3 FIRST AID PROCEDURES

Decomposition of fertilizers can lead to the release of toxic gases: ammonium containing materials (e.g. urea, DAP, AS and AN) may give off ammonia and products containing nitrate may give off oxides of nitrogen. Oxides of nitrogen (variously known as nitrous fumes,  $\text{NO}_x$ , and nitrogen oxides) are particularly toxic and the effects of their inhalation may be delayed and lead to pulmonary oedema (fluid in the lung). Ammonia gas is comparatively less toxic; but may produce similar delayed effects.

Any person who has definitely inhaled oxides of nitrogen or ammonia gas must be removed from the fumes, made to lie down in shade, kept warm and made to rest even though no symptoms may be evident.

Give oxygen, especially if the person is blue in the face.

Apply artificial respiration only if breathing fails.

Seek immediate medical help and keep the affected person under medical supervision for at least 48 hours. Hospital treatment is preferred.

## 19. REFERENCES

- 1 Handbook for the Safe Storage of Ammonium Nitrate Based Fertilizers, Guidance from IFA/APEA (1992).
- 2 Guidance for Safe Handling and Use of Non-conforming Fertilizers and Related Materials for Producers. Published by EFMA (2003).
- 3 Guidance for Safe Handling and Utilization of Non-conforming Solid Fertilizers and Related Materials for Fertilizer Importers, Distributors and Merchants. Published by EFMA (2004).
- 4 EFMA Product Stewardship programme. See <http://www.efma.org/>
- 5 Regulation 2003/2003/EC of the European Parliament and of the Council of 13 October 2003 relating to fertilizers. OJ304/1 20.11.2003.
- 6 Guidance for Compatibility of Fertilizer Blending Materials, published by EFMA (2006).
- 7 European Standard, EN 12944: 1999 (3 parts): Fertilizers and Liming Materials – Vocabulary.
- 8 a) European Standard, EN 1482-1: 2007 Fertilizers and Liming Materials: Sampling.  
b) Thompson D C, Practical and Theoretical Aspects of Fertiliser Sampling The International Fertiliser Society, Proceedings 533 (2004).
- 9 Shah K D, Safety of Ammonium Nitrate Fertilisers, The International Fertiliser Society, Proceedings 384 (1996).
- 10 Shah K D & Roberts A G, Nitric Acid and Fertilizer Nitrates, edited by Keleti, Publ. Marcel Dekker, ISBN 0-8247-7332-2, Chapter 10.
- 11 Laurent B, Straight Ammonium Nitrate Fertilizer Granule-prill Stabilization: Theoretical Possibilities. IFA Technical Conference, Chennai, (2002).
- 12 Clayton W E, Humidity Factors Affecting Storage and Handling of Fertilizers, Publ International Fertilizer Development Corporation (1984).



- 13 a) Stephen H and Stephen T, Solubility of Inorganic and Organic Compounds, vol.1, part 1 (1963), p. 217.
- b) Gmelins Handbuch der Anorganischen Chemie, 8. Edition, Volume 23, pages 261 – 289.
- c) Ullmann's Encyclopedia of Industrial Chemistry, 2005 Wiley-VCH Verlag GmbH & Co, KGaA, 7th Edition, Ammonium Compounds.
- 14 BASF Material safety data sheet (MSDS), Revision 3.0 of 03.01.2005.
- 15 Gmelins Handbuch der Anorganische Chemie. Teil D1, Volume 14, Verlag-Chemie, GMBH, Weinheim/Bergstrasse, 1971.
- 16 Ind. Eng. Chem. 26 (1936) 5,517-522.
- 17 Sauchelli V, The Chemistry and Technology of Fertilizers, Published by American Chemical Society, 1960.
- 18 Data supplied by Yara International ASA, 2005.
- 19 Gmelins Handbuch der Anorganische Chemie, Teil B, Lieferung 3, Syst.nr.28, Verlag Chemie, GMBH, Weinheim/Bergstrasse, 1961.
- 20 Moldovan I, Popovici N and Chivu G, The Technology of Mineral Fertilizers, British Sulphur Corporation Ltd., 1969; p299.
- 21 MSDS from Kali and Salz.
- 22 Shah K D and Thompson D C, Ammonium Nitrate: Safety Aspects of Blended and Granulated Compound Fertilisers based on Ammonium Nitrate, The International Fertilizer Society, Proceedings 448, (2000).
- 23 Perbal G, Thermal Stability of Fertilizers containing Ammonium Nitrate The International Fertiliser Society Proceedings 124 (1971).
- 24 Kiiski H, Ammonium Nitrate: Self-Sustaining Decomposition of NPK Fertilizers Containing Ammonium Nitrate, The International Fertiliser Society, Proceedings 450 (2000).
- 25 Feick G and Hainer R M (1954), On the thermal decomposition of ammonium nitrate. Steady state reaction temperatures and reaction rate. J. Am. Chem. Soc. Vol 76, p5860-5863.
- 26 UN Recommendations on the Transport of Dangerous Goods: Manual of Tests and Criteria. Fourth revised edition, 2003. ISBN 92-1-139087-7-0.
- 27 Groothuizen Th M and Heemskerk, Investigations into the Initiation of Molten Ammonium Nitrate by Falling Objects, IFA Technical Conference, Edmonton, August 1988.
- 28 Etching: Safety Guide For Fertilizer Storage Facility Made (partly or totally) of Wood, Published June 2004, source: UNIFA.
- 29 Greiner Maurice, Ammonium Nitrate fertilizer – Exploding the Myth, AIChE, Ammonia Safety Symposium, 1984.
- 30 EFMA, Guidance for the Storage of Hot Ammonium Nitrate Solutions, 2005.
- 31 Communication to EFMA from SKW, Piesteritz, Germany, concerning tests performed by BAM.
- 32 CF Industries, Inc., Material Safety Data Sheets.
- 33 Council Directive 67/548/EEC of 27 June 1967 on the approximation of laws, regulations and administrative provisions relating to the classification, packaging and labelling of dangerous substances. OJ 196, 16.8.1967, p 1 (as amended).
- 34 Globally Harmonized System of Classification and Labelling of Chemicals (GHS), 2005, published by UN, ISBN 92-1-116927-5.
- 35 UN Recommendation on the Transport of Dangerous Goods ("Orange book"): Model regulations. 14th revised edition, 2005. United Nations Publication ISBN 92-1-139106-7.

- 36 Seveso Directive 2003/105/EC of the European Parliament and of the Council of 16 December 2003 amending Council Directive 96/82/EC on the control of major-accident hazards involving dangerous substances. OJ L 345 31.12.2003 pages 97-105.
- 37 IMO: International Maritime Dangerous Goods Code (IMDG), two volumes. IMO Publications, London.
- 38 BC Code: Code of Safe Practice for Solid Bulk Cargoes, IMO, London, 2005.
- 39 a) European Agreement Concerning the International Carriage of Dangerous Goods by Road (ADR). Edition 2005. Volumes I and II. United Nations Publication ISBN 92-1-139097-4.
- b) Council Directive 94/55/EC of 21 November 1994 on the approximation of the laws of the Member States with regard to the transport of dangerous goods by road OJ L319,12.12.1994, p.7 as amended several times.
- 40 a) RID: Regulations concerning the international carriage of dangerous goods by rail, 2005 edition.
- b) Council Directive 96/49/EC of 23 July 1996 on the approximation of the laws of the Member States with regard to the transport of dangerous goods by rail OJ L 235, 17.09.1996 P. 0025 - 0030 as amended.
- 41 IATA Dangerous goods regulations, published by IATA.
- 42 European Agreement concerning the International Carriage of Dangerous Goods by Inland Waterways (ADN) UN 2005. ISBN 92-1-139102-4.
- 43 ADN: Accord Européen relatif au transport international des marchandises dangereuses par voie de navigation du Rhin (European convention over the international transport of dangerous goods on the Rhine) (danger property transport).
- 44 Kiiski H, Micronutrient Inclusion in Fertilisers: Safety and Compatibility, The International Fertiliser Society, Proceeding 546 (2004).
- 45 <http://www.icca-chem.org/pdf/icca009.pdf>
- 46 REACH proposal: COM (2003) 644 final, Commission of European Communities, Brussels.
- 47 Regulation (EC) No 725/2004 of the European Parliament and of the Council of 31 March 2004 on enhancing ship and port facility security. OJ L129 29.4.2004.
- 48 Leyshon D, Increased Emphasis on Quality, Fertilizer International, No. 379, November/December 2000, pages 33 ff.
- 49 Council Directive 96/35/EC of 3 June 1996. On the appointment and vocational qualification of safety advisers for the transport of dangerous goods by road, rail and inland waterways. OJ L145 p10 19.06.1996 as amended.
- 50 CEFIC, Industry Guidelines for the Security of the Transport of Dangerous Goods by Road, CEFIC, Brussels (2005).
- 51 EFMA, Guidance for Sea Transport of Ammonium Nitrate Based Fertilizers (2004).
- 52 Atkinson G and Adams W D, Ammonium Nitrate: Toxic Fume Risk from Fires in Storage, Proceedings 496, International Fertiliser Society, 2004.
- 53 Kersten R and Mak W A, Explosion Hazards of Ammonium Nitrate, How to Assess Risks? Paper presented at the International Symposium on Safety in the Manufacture, Storage, Use, Transport and Disposal of Materials, Tokyo, 10-12 March 2004.
- 54 Kersten R J A, van den Hengel EI V and van der Steen A C, Safety Testing of Ammonium Nitrate Products, Proceedings 580, International Fertiliser Society, 6 April 2006.

## 20. ABBREVIATIONS

ADR	Agreement concerning the international carriage of dangerous goods by road (French)
ADN	European Agreement concerning the International Carriage of Dangerous Goods by Inland Waterways
AIC	Agricultural Industries Confederation (GB)
AIChE	American Institute of Chemical Engineering
AN	Ammonium Nitrate
ANFO	Ammonium Nitrate Fuel Oil
ANS / ANAS	Ammonium Nitrate Sulphate Ammonium nitrate solution
APEA	Association des Producteurs Européens d'Azote
AS	Ammonium Sulphate
BAM	Bundesanstalt für Materialforschung und prüfung
BC	Bulk Cargo
CAN	Calcium Ammonium Nitrate
CAS	Chemical Abstracts Service
CEFIC	Conseil Européen de l'Industrie Chimique (European Chemical Industry Council)
CEN	Comité Européen de Normalisation (European Committee for Standardisation)
COMAH	Control of Major Accident Hazards involving Dangerous Substances
COP	Codes of Practice

CPL	Classification, Packaging and Labelling
CRH	Critical Relative Humidity
DAP	Diammonium Phosphate
DGSA	Dangerous Goods Safety Advisor
DIN	Deutsches Institut für Normung
EC	European Community, European Council
EEC	European Economic Community
EFMA	European Fertilizer Manufacturers' Association
EINECS	European Inventory of Existing Commercial Chemical Substances
EN	European Norme
EQS	Environmental Quality Standards
ERIC	Emergency Response Intervention Cards
EU	European Union
GHS	Globally Harmonized System
HPV	High Production Volume chemicals
HSE	Health & Safety Executive (authority the UK)
IATA	International Air Transport Association
IBC	Intermediate Bulk Container
ICCA	International Council of Chemical Associations
IFA	International Fertilizer Industry Association
IFDC	International Fertilizer Development Centre
IFS	The International Fertiliser Society
IMDG	International Maritime Dangerous Goods (Code)
IMO	International Maritime Organisation (Transport at sea)
IPCC	Intergovernmental Panel on Climate Change
MAP	Monoammonium Phosphate
MOP	Muriate of Potash (Potassium Chloride)
MSDS	Material Safety Data Sheet
NO <sub>x</sub>	Nitrogen oxides
NOP	Nitrate of Potash, Potassium nitrate
NPK	Fertilizer containing the nutrients Nitrogen, Phosphorus & Potassium
PDV	Productschap voor DierVoeder ( the Netherlands )
REACH	Registration, Evaluation, Authorisation and Restrictions of Chemicals
RID	Regulations concerning International carriage of Dangerous goods by rail
SDS	Safety Data Sheet
SOP	Sulphate of Potash (Potassium Sulphate)
SSD	Self-Sustaining Decomposition
SSP	Single Superphosphate

TARMAC	Company in UK selling cement, asphalt, etc.
TFI	The Fertilizer Institute in the USA
TNO	Netherlands' Organisation for Applied Scientific Research
TSP	Triple Superphosphate
UAN	Urea Ammonium Nitrate
UN	United Nations
VKP	The Netherlands' National Association of Fertilizers Producers (Vereniging voor Kunstmest Fabrikanten)

## APPENDIX 1

### CLASSIFICATION OF FERTILIZERS UNDER THE UN SCHEME

There were several entries for these products prior to the year 2001, when they were rationalised and simplified. The main changes were:

- Deleted 0223, 2068-2070 and 2072.
- Rationalised and combined 2067, 2068, 2069 and 2070 into a new 2067.
- New Special Provisions: 306 and 307.
- Changed Shipping Name to: Ammonium Nitrate Based Fertilizer

In December 2006 a proposal to amend special provision 307 b) was approved by the relevant UN body, see Section 7.3.1 of this guidance.

#### SPECIAL PROVISION 193

This entry may only be used for uniform ammonium nitrate based fertilizer mixtures of the nitrogen, phosphate or potash type, containing not more than 70% ammonium nitrate and not more than 0.4% total combustible/organic material calculated as carbon or with not more than 45% ammonium nitrate and unrestricted combustible material. Fertilizers within these composition limits are only subject to these Regulations when transported by air or sea and are not subject to these Regulations if shown by a Trough Test (see Manual of Tests and Criteria, Part III, Sub-Section 38.2) not to be liable to self-sustaining decomposition.

#### SPECIAL PROVISION 307

This entry may only be used for uniform mixtures containing AN as the main ingredient within the following composition limits:

- a) Not less than 90% AN with not more than 0.2% total combustible/organic material calculated as carbon and with added matter, if any, which is inorganic and inert towards AN;  
or
- b) Less than 90% but more than 70% AN with other inorganic materials or more than 80% but less than 90% AN mixed with calcium carbonate and/or dolomite and not more than 0.4% total combustible/organic material calculated as carbon;  
or
- c) Nitrogen type AN-based fertilizers containing mixtures of AN and AS with more than 45% but less than 70% AN and not more than 0.4% total combustible/organic material calculated as carbon such that the sum of the percentage compositions of AN and AS exceeds 70%.

It is worth noting that for mixtures of AN and AS only Special Provision 307 c) applies. Straight N fertilizers in the form of mixtures of AN and AS containing more than 70% AN are considered more hazardous than those covered by 307 c) and, therefore, the Special Provision 307 should not be applied for safety reasons).

## UN CLASSIFICATION OF AN-BASED FERTILIZERS

Fertilizer Composition	AN Content	Combustible Material (maximum)	UN Number	SP No.
AN + added matter, if any, which is inorganic & inert towards AN See Note 1	> 90%	0.2%	2067	307 a)
AN + other inorganic materials e.g. phosphate/potash sources See Note 2	70 - 90%	0.4%	2067	307 b)
AN + calcium carbonate and/or dolomite	80 - 90%	0.4%	2067	307 b)
AN + ammonium sulphate	45 - 70% (Where AN + AS > 70%)	0.4%	2067	307 c)
AN-based NPK, capable of SSD	45 - 70%	0.4%C	2071	193
AN-based NPK capable of SSD	0 - 45%	unrestricted	2071	193

Note 1: Ammonium nitrate of technical or industrial grade i.e. non-fertilizer grade belongs to UN No.1942, oxidizing, class 5.1 under the UN classification system.

Note 2: It should be noted that some compound (NPK or NK) fertilizers of this class can also exhibit the self-sustaining decomposition (SSD) property (see Section 7.4 of this guidance). However, this is rather uncommon and the oxidizing classification, i.e. class 5.1, takes precedence.

## APPENDIX 2

### PROVISIONS OF SEVESO II DIRECTIVE

Dangerous substances	Qualifying quantity (tonnes) for the application of	
	Articles 6 and 7	Article 9
<p>1. Ammonium nitrate: fertilisers capable of self-sustaining decomposition</p> <p>This applies to ammonium nitrate based compound/composite fertilisers (compound/composite fertilisers containing ammonium nitrate with phosphate and/or potash) in which the nitrogen content as a result of ammonium nitrate is</p> <ul style="list-style-type: none"> <li>– between 15.75% and 24.5% by weight, and either with not more than 0.4% total combustible/organic materials or which fulfil the requirements of Annex II of Directive 80/876/EEC</li> <li>– 15.75% by weight or less and unrestricted combustible materials</li> </ul> <p>and which are capable of self-sustaining decomposition according to the UN Trough Test (see United Nations Recommendations on the Transport of Dangerous Goods: Manual of Tests and Criteria, Part III, subsection 38.2).</p>	5000	10000
<p>2. Ammonium nitrate: fertiliser grade</p> <p>This applies to straight ammonium nitrate based fertilisers and to ammonium nitrate based compound/composite fertilisers in which the nitrogen content as a result of ammonium nitrate is</p> <ul style="list-style-type: none"> <li>– more than 24.5% by weight, except for mixtures of ammonium nitrate with dolomite, limestone and/or calcium carbonate with a purity of at least 90%</li> <li>– more than 15.75% by weight for mixtures of ammonium nitrate and ammonium sulphate</li> <li>– more than 28% by weight for mixtures of ammonium nitrate with dolomite, limestone and/or calcium carbonate with a purity of at least 90%</li> </ul> <p>and which fulfil the requirements of Annex II of Directive 80/876/EEC.</p>	1250	5000
<p>3. Ammonium nitrate: technical grade</p> <p>This applies to:</p> <ul style="list-style-type: none"> <li>– ammonium nitrate and preparations of ammonium nitrate in which the nitrogen content as a result of the ammonium nitrate is                             <ul style="list-style-type: none"> <li>– between 24.5% and 28% by weight, and which contain not more than 0.4% combustible substances</li> <li>– more than 28% by weight, and which contain not more than 0.2% combustible substances</li> </ul> </li> <li>– aqueous ammonium nitrate solutions in which the concentration of ammonium nitrate is more than 80% by weight.</li> </ul>	350	2500
<p>4. Ammonium nitrate: “off-spec” material and fertilisers not fulfilling the detonation test</p> <p>This applies to:</p> <ul style="list-style-type: none"> <li>– material rejected during the manufacturing process and to ammonium nitrate and preparations of ammonium nitrate, straight ammonium nitrate based fertilisers and ammonium nitrate based compound/composite fertilisers referred to in notes 2 and 3, that are being or have been returned from the final user to a manufacturer, temporary storage or reprocessing plant for reworking, recycling or treatment for safe use, because they no longer comply with the specifications of Notes 2 and 3</li> <li>– fertilisers referred to in note 1, first indent, and Note 2 which do not fulfil the requirements of Annex II of Directive 80/876/EEC.</li> </ul>	10	50
<p>5. Composite potassium nitrate based fertilizers composed of potassium nitrate in prilled/granular form</p>	5000	10000
<p>6. Composite potassium nitrate based fertilizers composed of potassium nitrate in crystalline form</p>	1250	5000

NOTE: toxic categories could include trace elements.



### APPENDIX 3

#### VICTOR LANCES

The Victor lance was developed by Gewerkschaft Victor and is especially useful to extinguish decompositions in small quantities of a few hundred tonnes or in piles of bagged fertilizers. The lance consists of a nozzle (see diagram) fitted to a tube of 3m length and a diameter of 25mm. If necessary this lance can be lengthened by connecting other 3m pieces with the aid of screw couplings. At a water pressure of 8 bars this nozzle has a water capacity of about 280 l/min. The lance is easy to handle and pierces through the fertilizer very quickly to reach the heart of the decomposition, even if the product is caked. Furthermore, extinguishing can be achieved with less water compared to a normal nozzle or spray.

Diagram of Nozzle of Victor lance with dimensions in mm

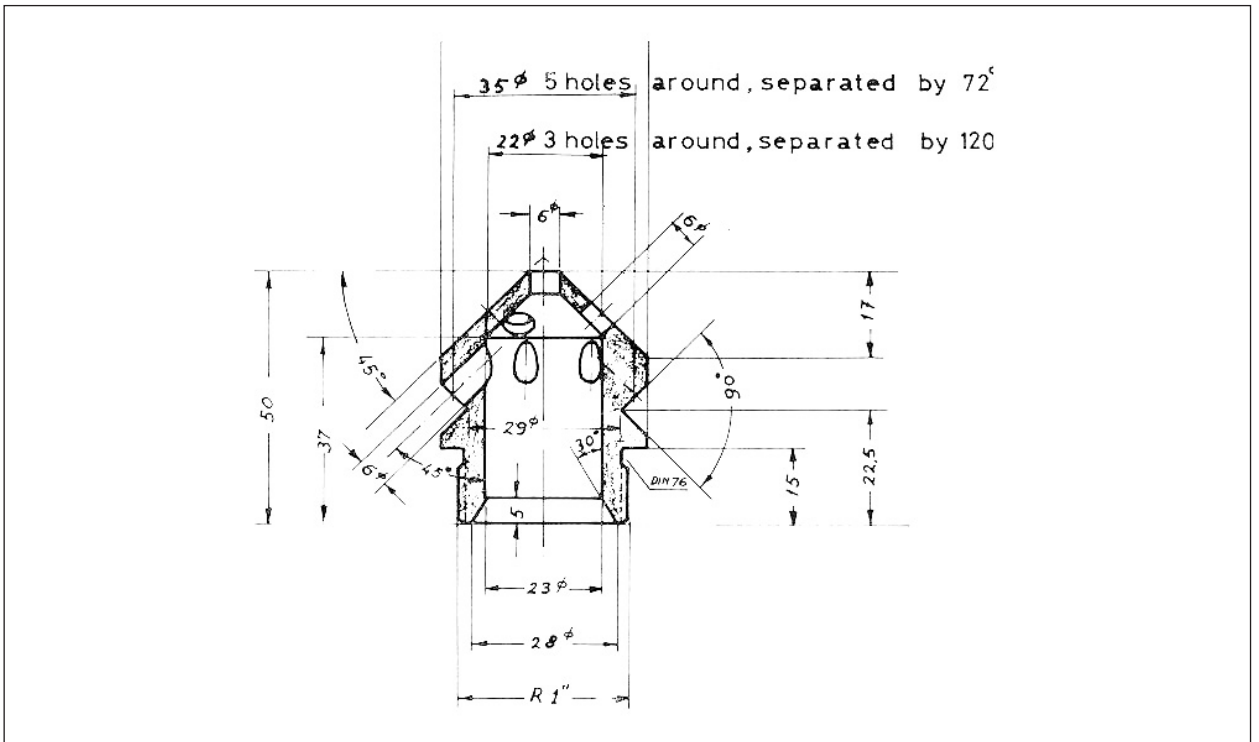





Avenue E. van Nieuwenhuyse, 4  
B-1160 Brussels  
Belgium  
Tel: +32 2 675 35 50  
Fax: +32 2 675 39 61  
E-mail: [main@efma.be](mailto:main@efma.be)

For more information about EFMA  
visit the web-site [www.efma.org](http://www.efma.org)